

- (A) Zastavbovy rozmer / In-built dimension / Baumaße
- (B) Litinový odvod kouře / Cast iron spigot / Der gusseiserne Rauchabgang
- (C) Centralni privod vzduchu / Central air inlet / Zentralluftzufuhr
- (D) Primarni a sekundarni vzduch / Primary and secondary air / Primärluft und Sekundärluft
- (L) Volna plocha proskleni / Free glass area / Freie Glassichtfläche

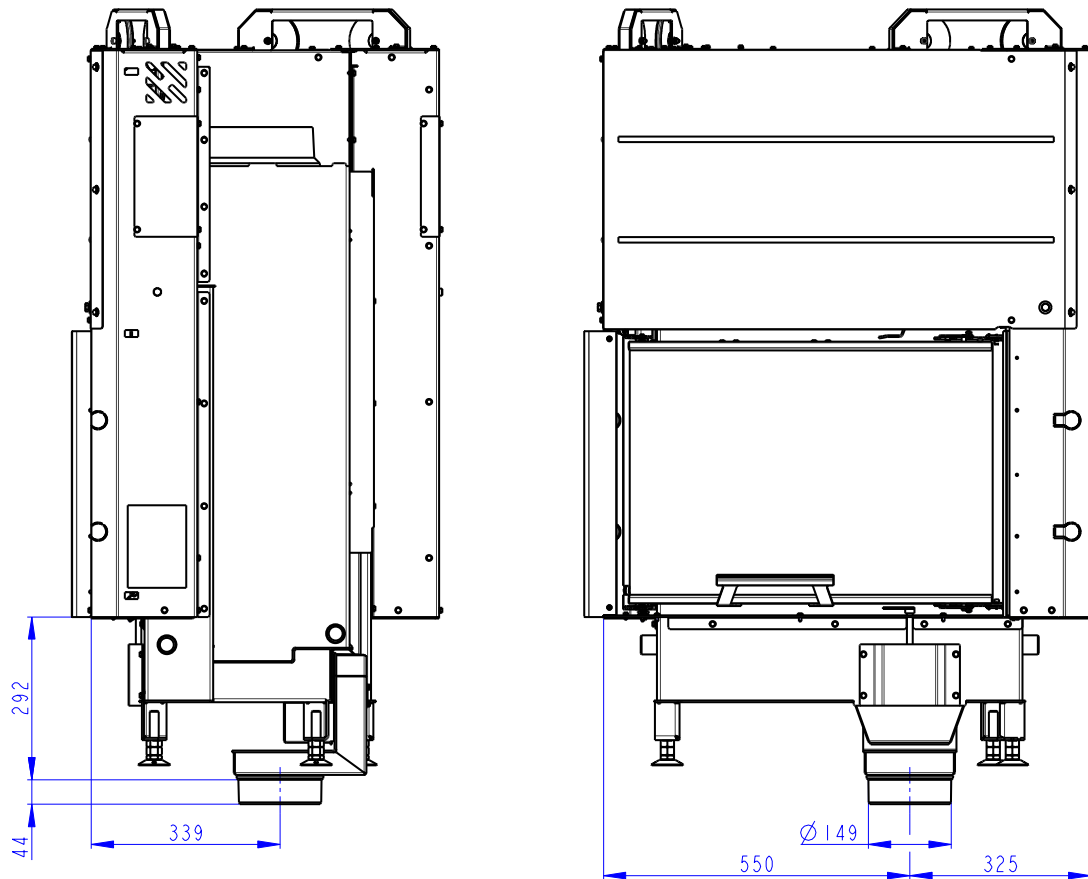

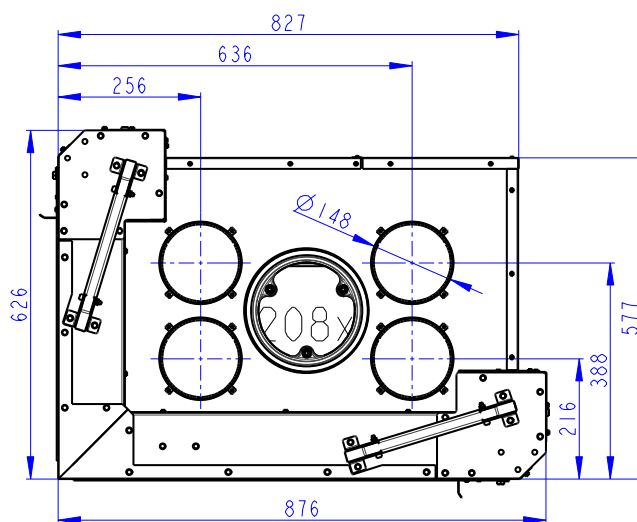

NELZE KOMBINOVAT SE SADAMI AKUMULACI AKKUM KV 02, AKKUM KV 04
UNABLE TO COMBINE WITH ACCUMULATION SETS AKKUM KV 02, AKKUM KV 04
NICHT KOMBINIERBAR MIT SPEICHERSATZ AKKUM KV 02, AKKUM KV 04

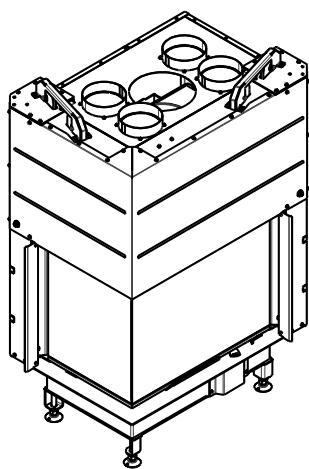
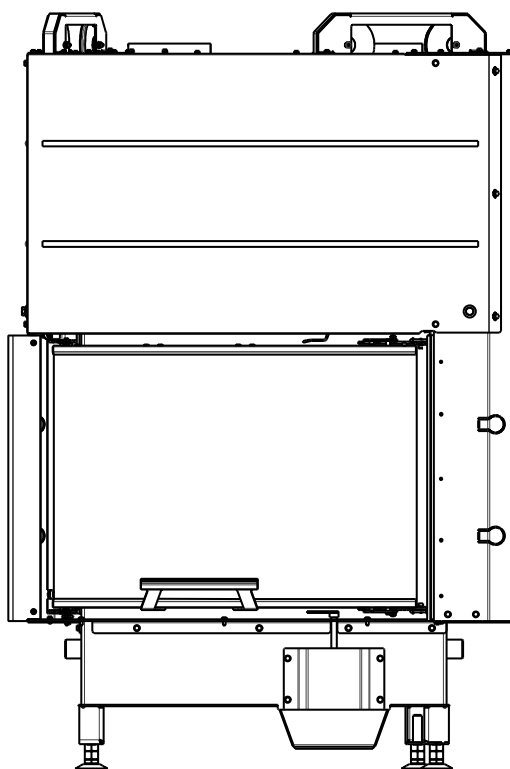
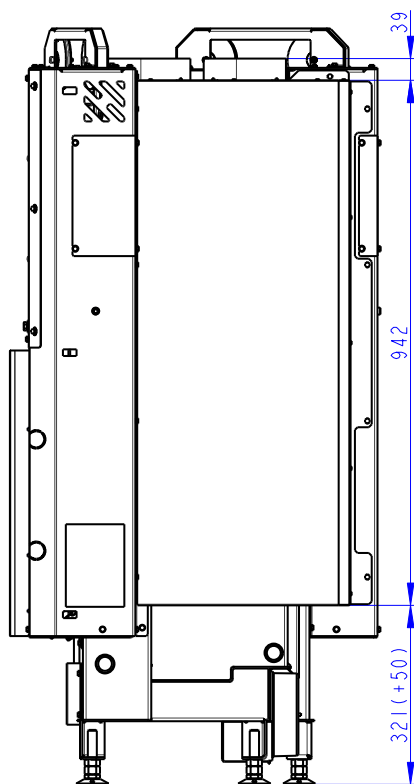
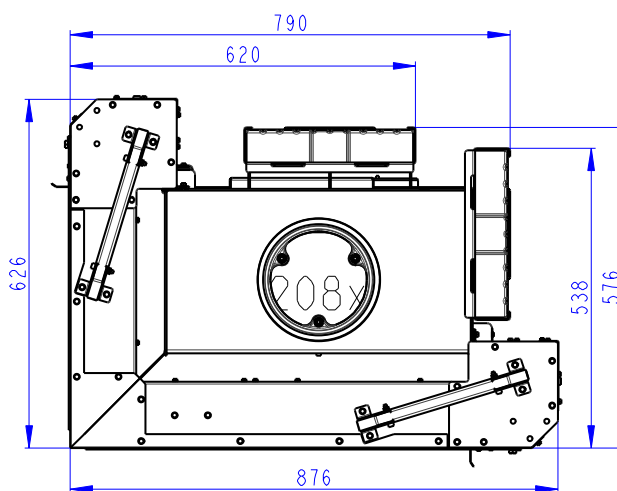
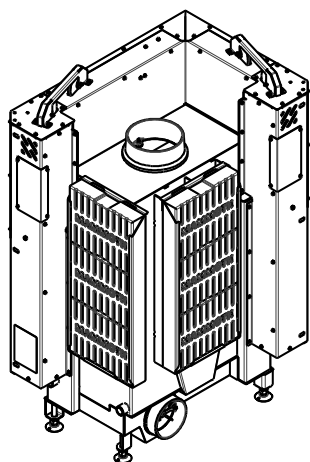
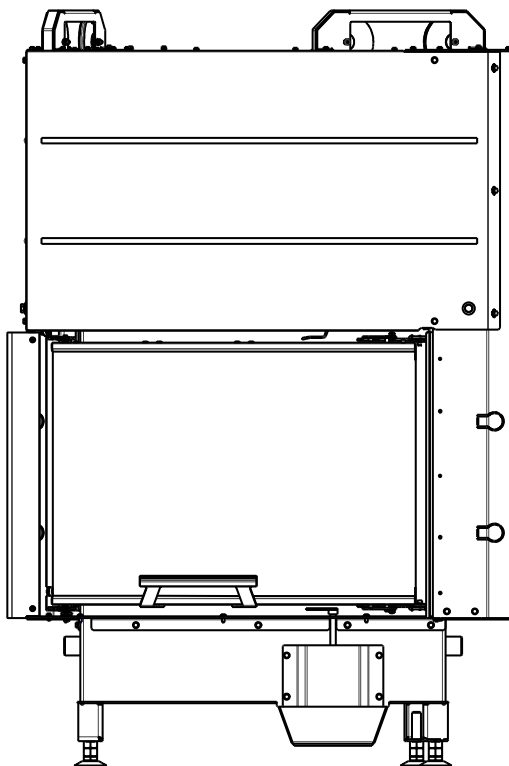
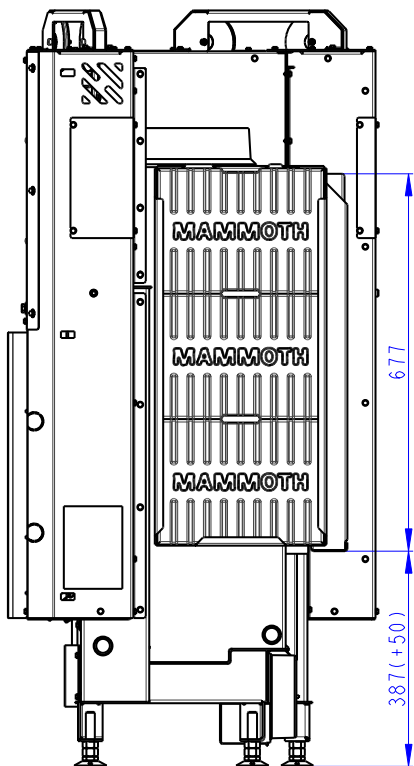

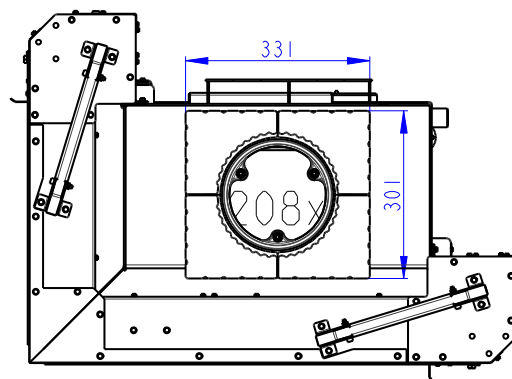
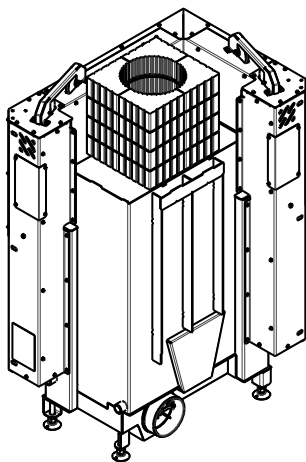
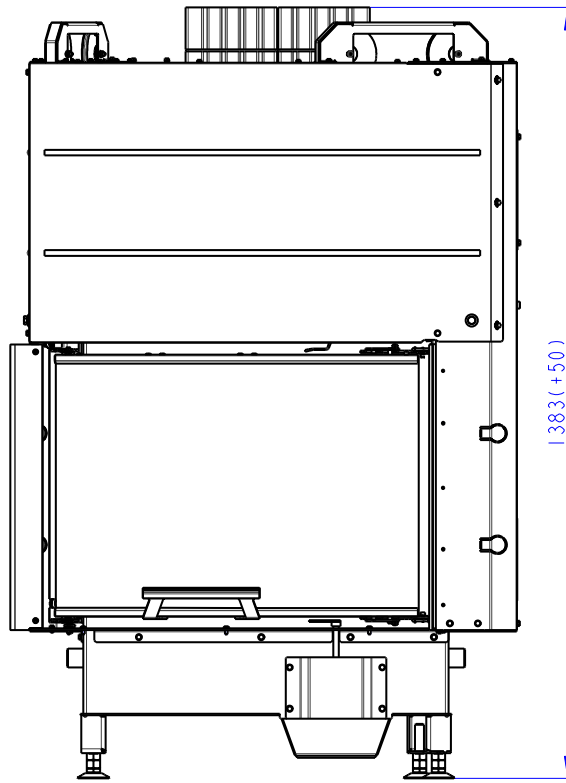
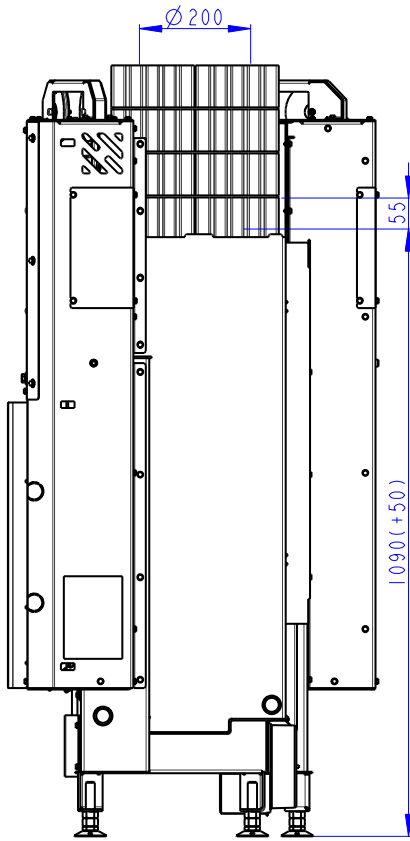

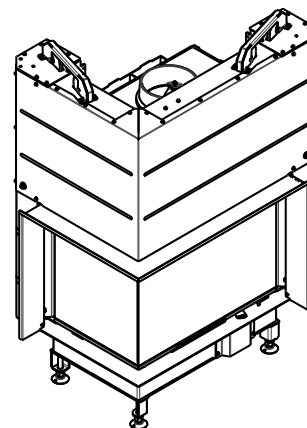
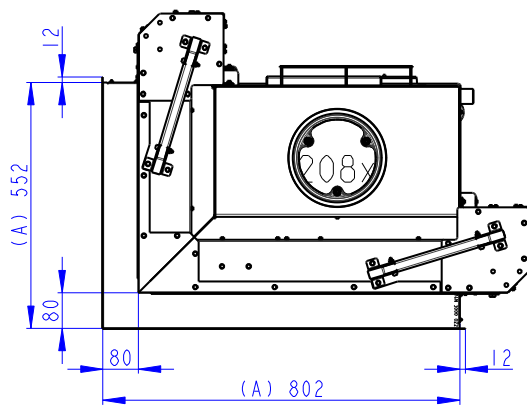
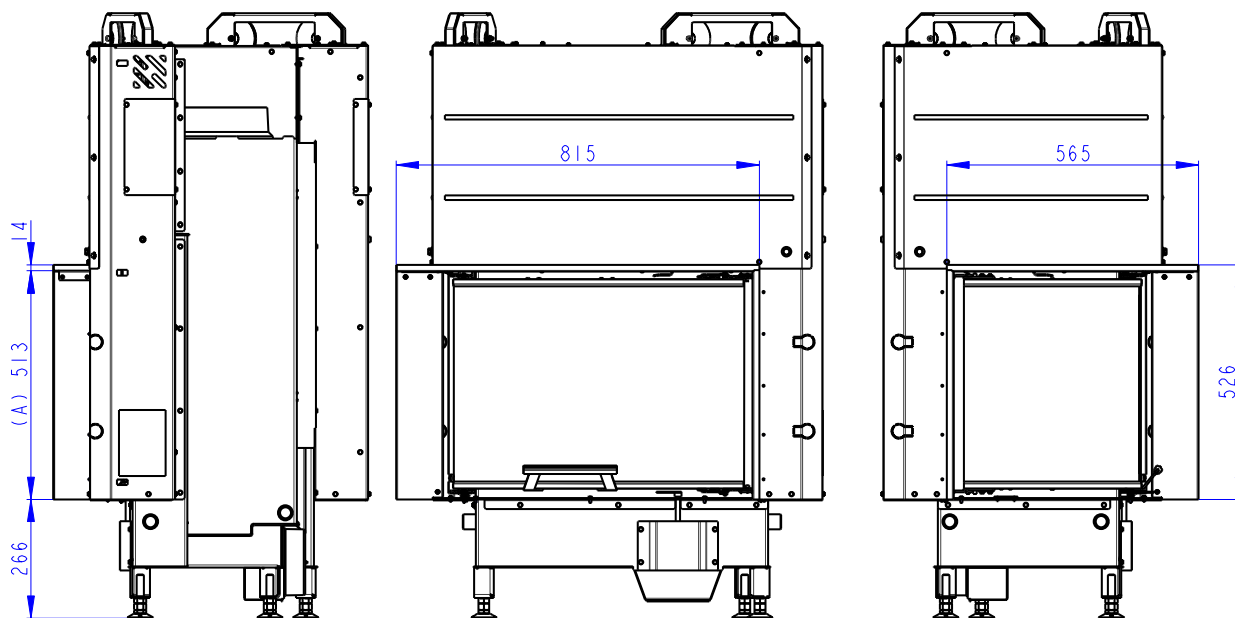

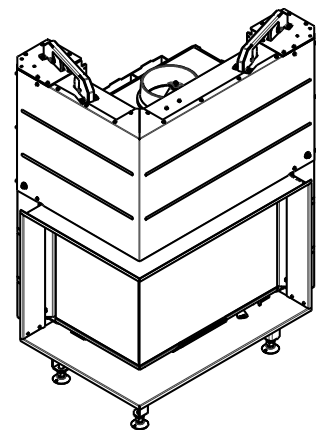
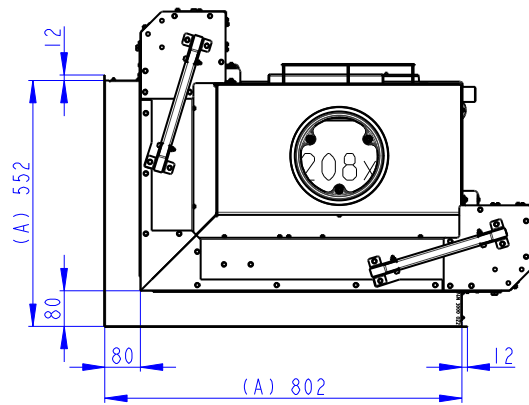
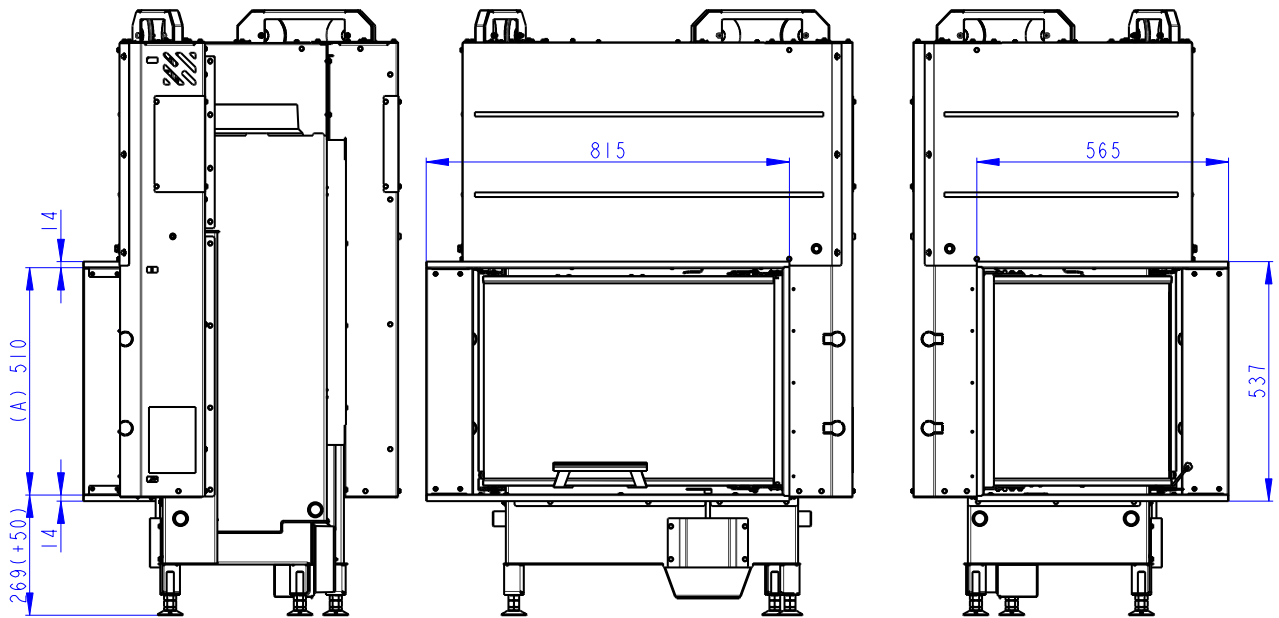

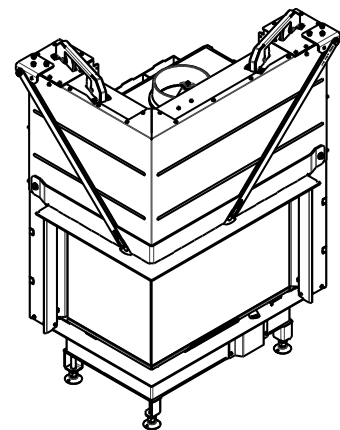
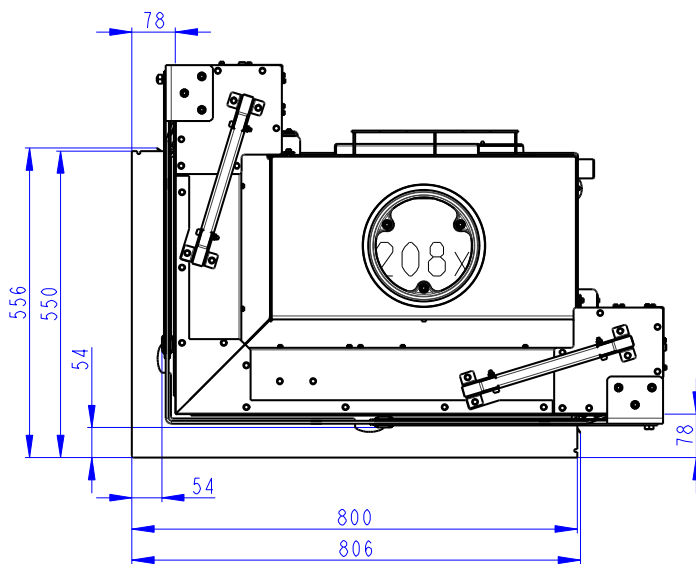
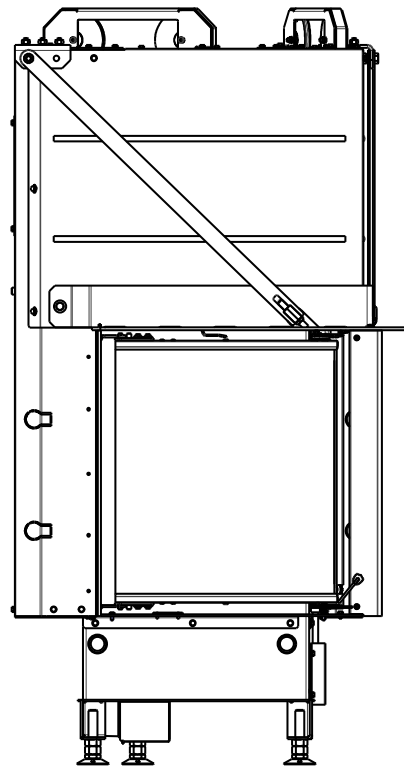
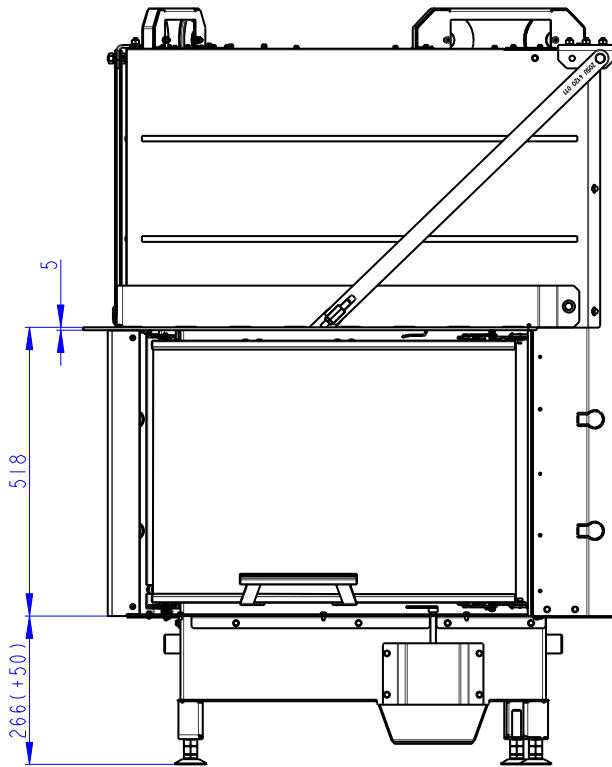

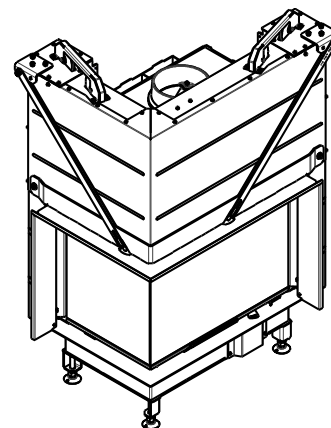
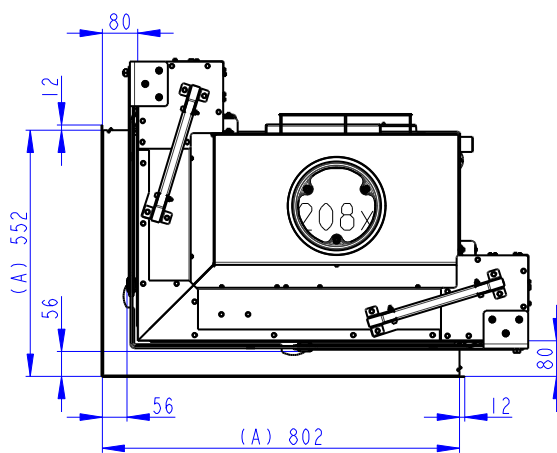
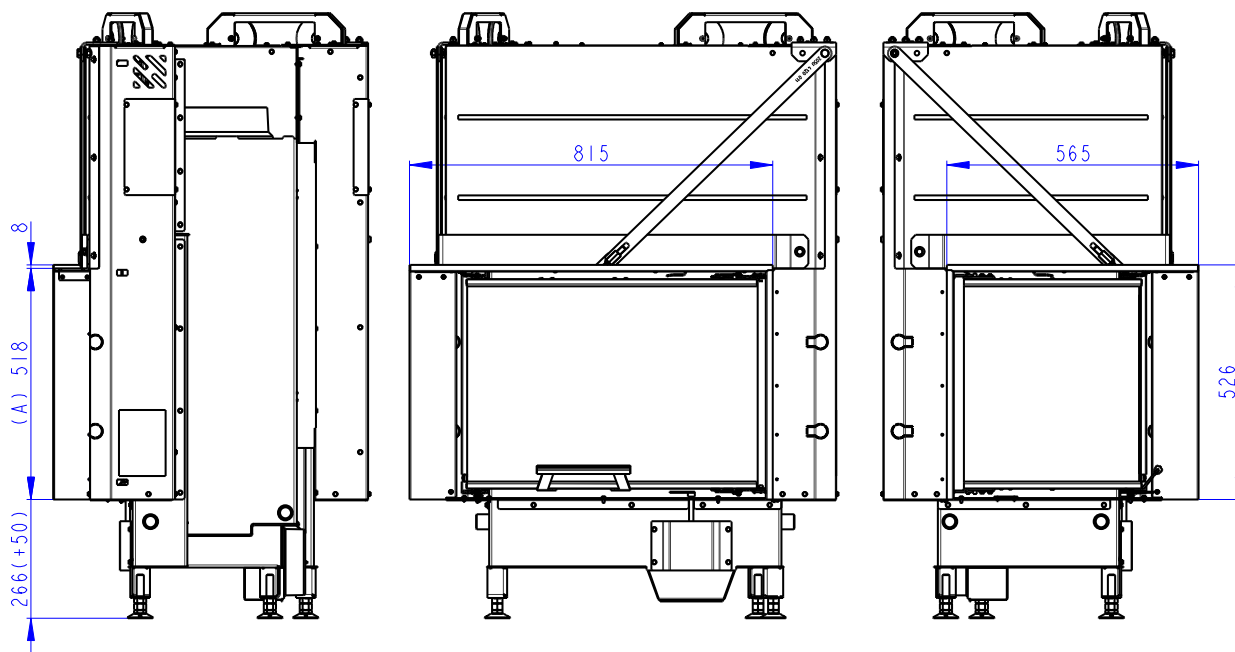

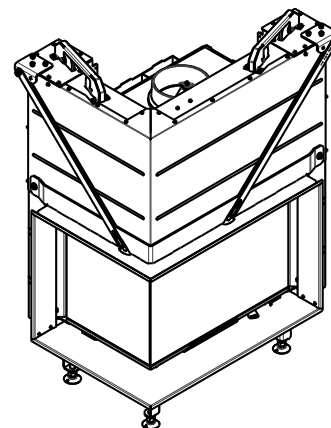
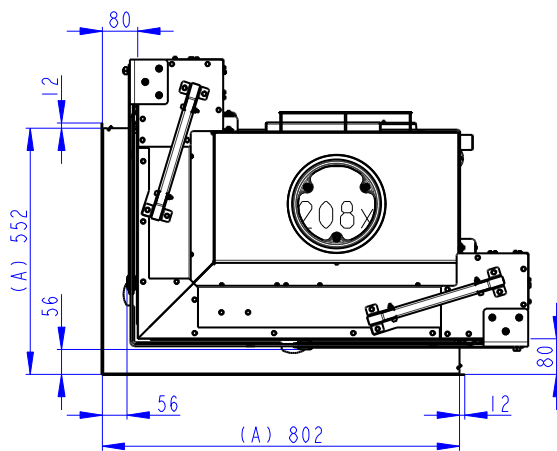
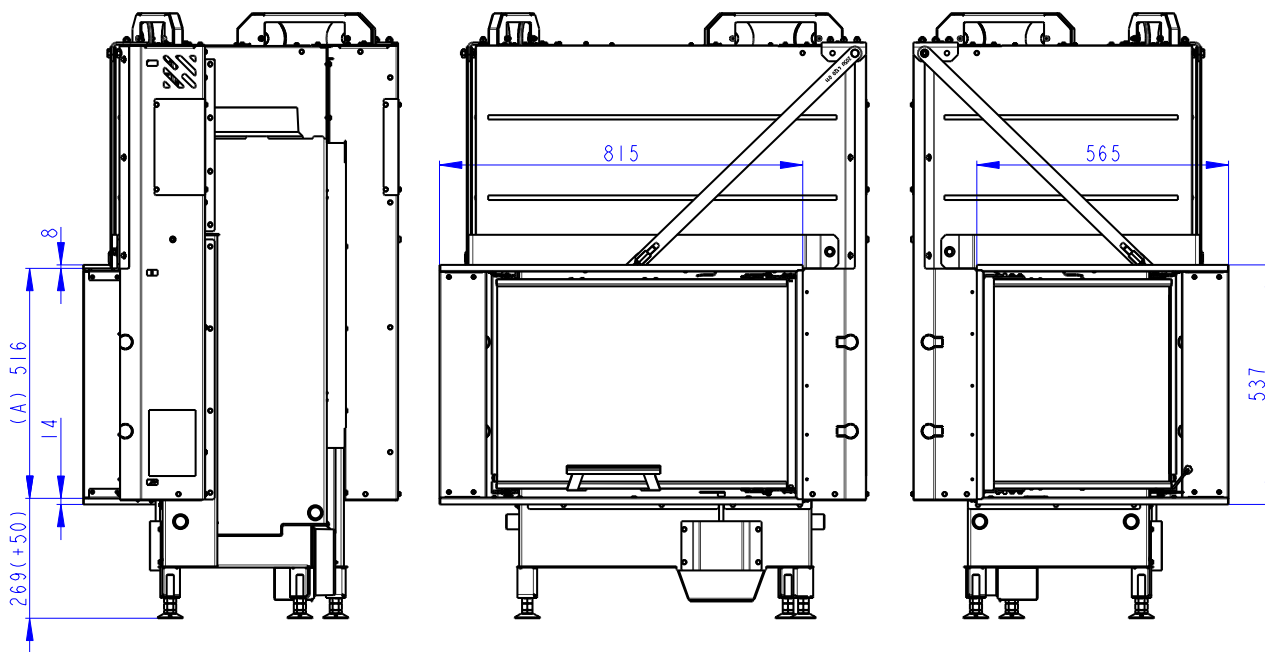

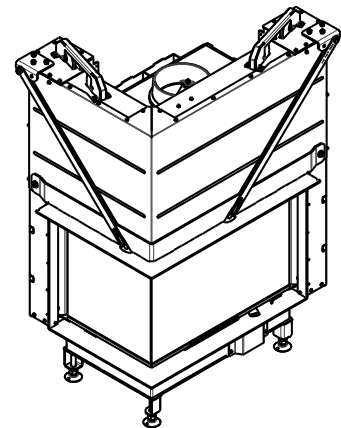
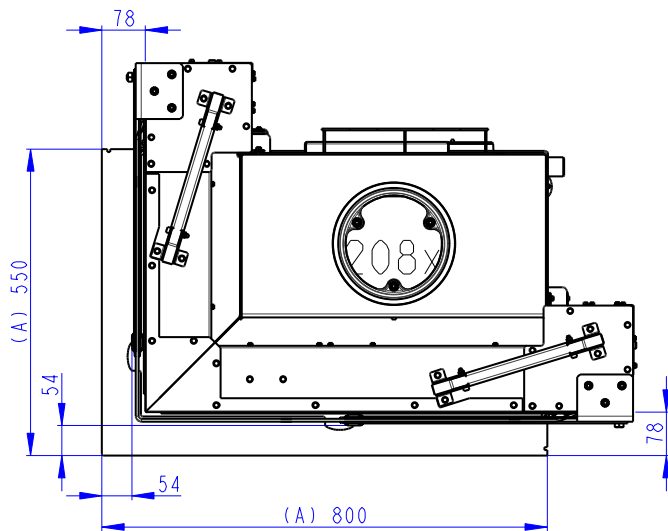
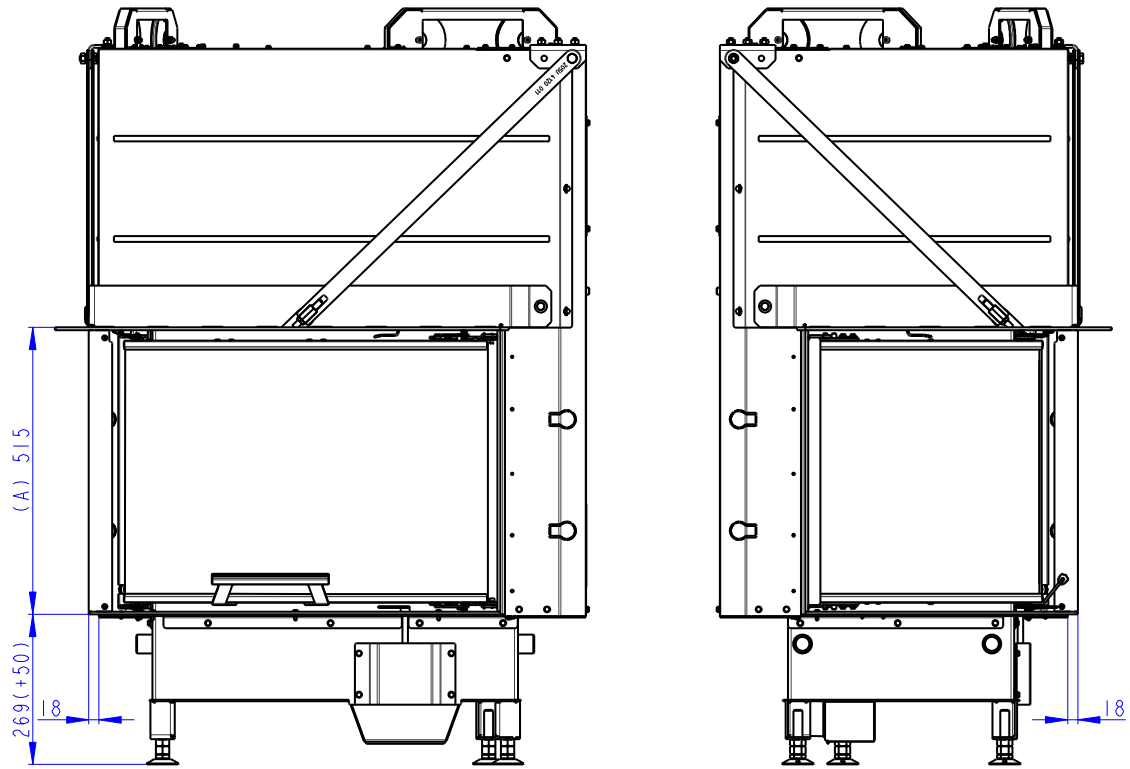

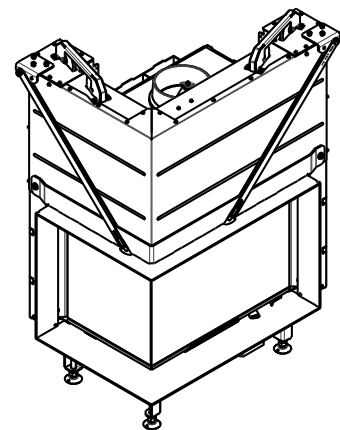
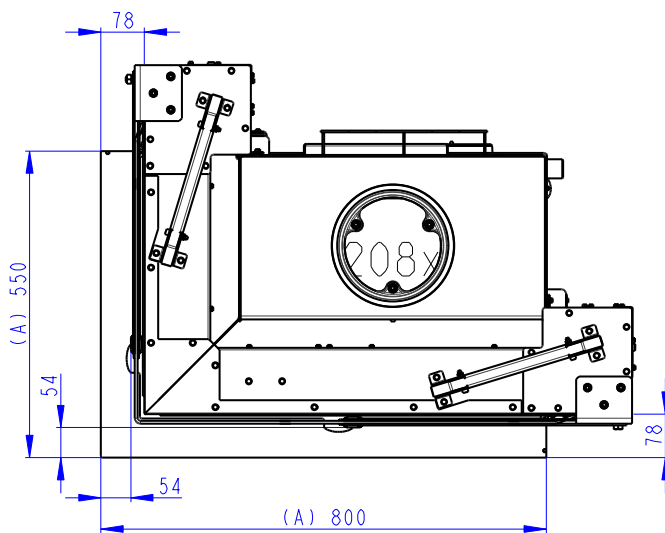
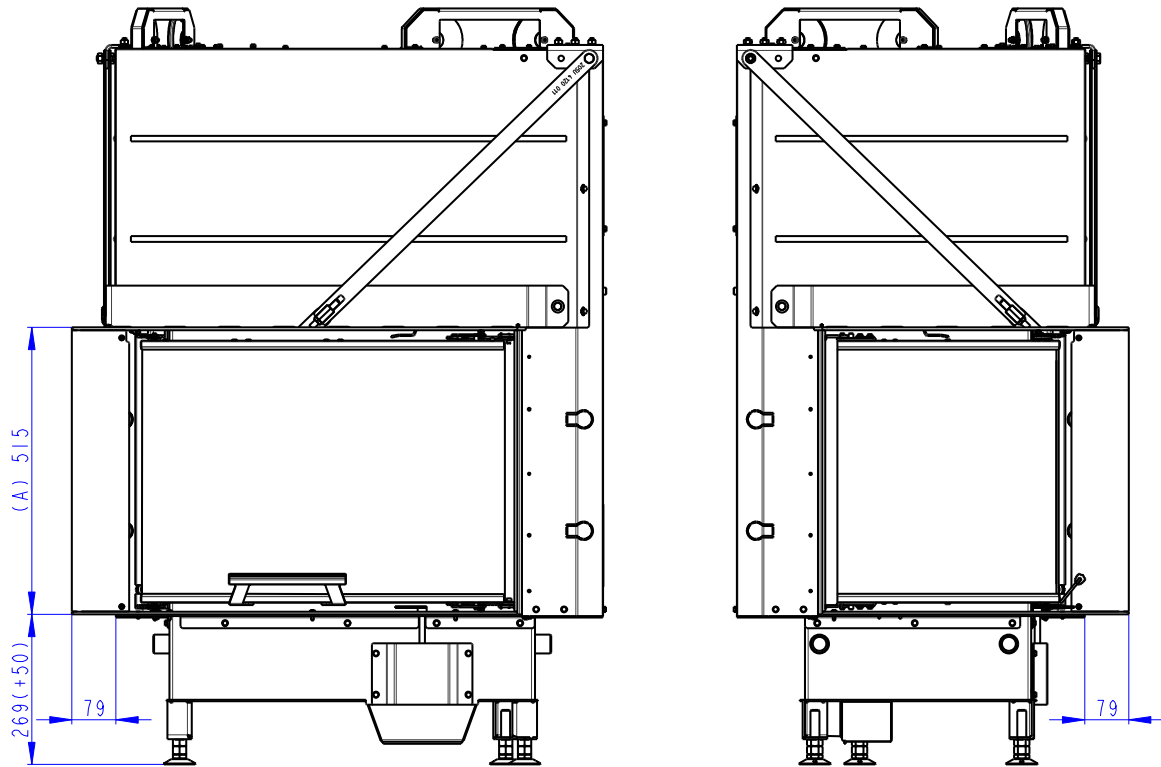

Declared qualities stated

 Harmonised technical specification ✓ EN 16510-1 ed.2:2023 | EN 16510-2-2:2022 ✓ Ecodesign ✓ DIN+ ✓ BlmSchV2 ✓ 15a B-VG 2015

Classification of appliance	Type BE			
		Nominal heat output (nom)	Part load heat output (part)	
Energy efficiency	η_{nom} η_{part}	81	---	%
Seasonal space heating energy efficiency at nominal heat output	$\eta_{s,nom}$ $\eta_{s,part}$	71	---	%
Energy Efficiency Index	EEI	107		
Energy label		A+		
Fuel		Wood logs		
Fuel length		180-350		mm
Average fuel consumption		3,12	---	kg/h
Allowed fuel dose		4,1		kg/h
Fuel supply interval		1 hour		
Base layer of fuel		0,31	---	kg
Criterion for the end of the test cycle		4,0	---	Vol.-%
Amount of combustion air		39,5		m ³ /h
Nominal heat output	P_{nom} P_{part}	10,4	---	kW
Hot-water exchanger nominal heat output	$P_{W,nom}$ $P_{W,part}$	---	---	kW
Maximum water operating pressure	p_W	---		bar
Dry flue gas mass flow rate	$\Phi_{f,g,nom}$ $\Phi_{f,g,part}$	9,4	---	g/s
Flue gas outlet temperature	$T_{s,nom}$ $T_{s,part}$	300	---	°C
Flue draught	p_{nom} p_{part}	12	---	Pa
Chimney temperature class		T400		
Connection to the common chimney		Yes		
Storage of fuel in the wood shed area		No		
Maximum warming of the wood in the wood shed		---		°C
Dust O ₂ = 13 %	PM_{nom} PM_{part}	33	---	mg/Nm ³
CO ₂		9,37	---	%
Emissions of gases of combustion (CO in the flue gases at O ₂ = 13 %)	CO_{nom} CO_{part}	0,0930 1162	---	% mg/Nm ³
OGC O ₂ = 13 %	OGC_{nom} OGC_{part}	53	---	mg/Nm ³
NOx O ₂ = 13 %	$NO_{x,nom}$ $NO_{x,part}$	79	---	mg/Nm ³
Automatic regulation unit of burning		---	---	
Electricity consumption in standby mode	$e_{l,SB}$	---		kW
Electricity consumption	$e_{l,max}$ $e_{l,min}$	---	---	kW
Intermittent operation Continuous operation	INT CON	INT		

Basic technical data

Principal dimensions (Height Width Length)	H W L	1357 876 626	mm
Combustion chamber dimensions	H W L	545 546 287	mm
Fireplace door dimensions	H W L	470 650 400	mm
Axis height of the rear (side) outlet		---	mm
Volume of hot-water exchanger		---	l
Flue diameter		200	mm
Diameter of flue throat	d_{out}	200	mm
Diameter of external air connection		150	mm
Maximum length (pipe) of external air intake		6000	mm
Weight	m	247	kg

Heat capacity
minimum size of the room of appliance installation

Insulation of the house – very good (20 W/m ³)	e.g. new, insulated house / permanently inhabited	308		m ³
Insulation of the house – good (22,5 W/m ³)		274		m ³
Insulation of the house – middle (32 W/m ³)		193		m ³
Insulation of the house – bad (45 W/m ³)		137		m ³
Insulation of the house – very bad (50 W/m ³)	e.g. old, uninsulated house / cottage / chalet	123		m ³

Distances from flammable materials
Note

Back	d_R	0		mm
Front	d_p d_{p1}	1000	800	mm
Front to the floor	d_F d_{F1}	340	300	mm
Side	d_s d_{s1}	270	270	mm
Side – niche	d_{s2}	---		mm
Side – location 45°	d_{s3}	---		mm
Side radiation	d_L d_{L1}	330	280	mm
From the floor	d_B	100		mm
From the ceiling	d_C	500		mm
From the back and side edge of the fireplace insert to the inside of the insulation	d_{s4}	120		mm

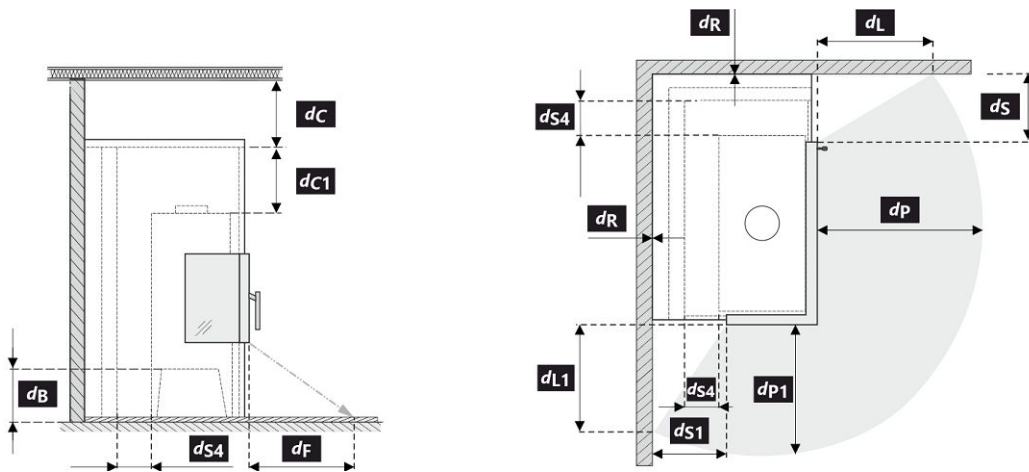

All local regulations, including regulations relating to national and European standards, must be observed during the installation and operation of the product.

Legend	Note	Description	Material	Dimension
1		Appliance	174Q 0000 003	
2		Flue gas outlet	metal	DN200
3		Insulation of the flue gas connection		
4		Mineral insulation		
5		Convection air space around the appliance		
6		Protective insulation of walls	SILCA 250	2x50 mm
6A		Protective ceiling insulation	SILCA 250	80 mm
7		Protective wall	hollow burnt brick	100 mm
8		Combustible wall		
9		Concrete slab		

10	Combustible floor		
11	Decorative / ornamental beam		
12	Beam with ventilation air gap		
13	Convection air inlet		700 cm ²
14	Convection air outlet		900 cm ²
15	Lining	SILCA 250	40 mm
16	Support frame		
17	Combustible ceiling		
18	Protective insulation board for combustible floors	SILCA 250	40 mm
19	Combustion air regulation		
20	Sheet metal cover if mineral wool is used		
21	If necessary, a floor protection plate under the appliance		
d_c	From the top of the exhaust vent to the combustible ceiling		500 mm
d_{c1}	– From the top of the fireplace insert to the underside of the ceiling insulation – In the case of an installed heat exchanger from the top edge of the heat exchanger to the underside of the ceiling insulation		300 mm 200 mm
d_{s4}	From the back and side edge of the fireplace insert to the inside of the insulation		120 mm
d_{s5}	From the front edge of the fireplace insert to the inside of the insulation		10 mm
d_B	From the bottom of the fireplace insert to the fireproof floor		100 mm

Caution: Fire protection / insulation boards SILCA® 250SB can be replaced by a suitable nonflammable material with a thermal conductivity (λ) $\leq 1,1 \text{ W}\cdot\text{m}^{-1}\cdot\text{K}^{-1}$.

Protective wall – hollow burnt brick (thickness 100 mm) can be replaced by a suitable nonflammable material with a thermal conductivity (λ) $\leq 0,36 \text{ W}\cdot\text{m}^{-1}\cdot\text{K}^{-1}$.

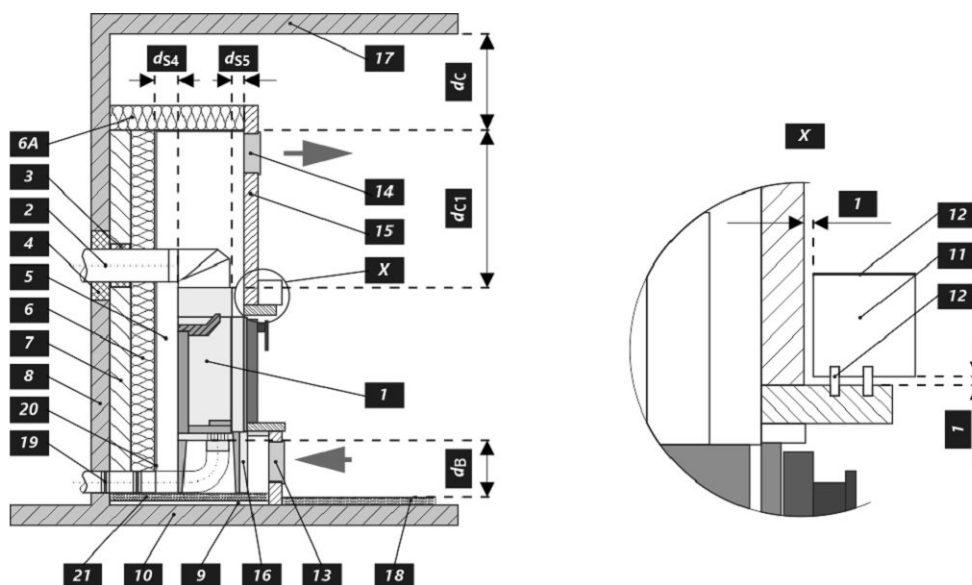

Deklarierte Produkteigenschaften

Harmonisierte technische Spezifikation ✓ EN 16510-1 ed.2:2023 | EN 16510-2-2:2022 ✓ Ecodesign ✓ DIN+ ✓ BImSchV2 ✓ 15a B-VG 2015

Produktklassifizierung		Type BE		
		Nennwärmeleistung (nom)	Teillastwärmeleistung (part)	
Energiewirkungsgrad	$\eta_{nom} \eta_{part}$	81	---	%
Raumheizungs-Jahresnutzungsgrad	$\eta_{Snom} \eta_{Spart}$	71	---	%
Energieeffizienzindex	EEI	107		
Energielabel		A+		
Brennstoff		Scheitholz		
Brennstofflänge		180-350		mm
Durchschnittlicher Brennstoffverbrauch		3,12	---	kg/h
Zulässiger Brennstoffverbrauch		4,1		kg/h
Brennstofflieferintervall		1 Stunde		
Grundglutmasse		0,31	---	kg
Kriterium für das Ende des Prüfzyklus		4,0	---	Vol.-%
Verbrennungsluftmenge		39,5		m ³ /h
Nennwärmeleistung	$P_{nom} P_{part}$	10,4	---	kW
Wärmetauscherleistung	$P_{Wnom} P_{Wpart}$	---	---	kW
Maximaler Wasserbetriebsdruck	P_W	---		bar
Rauchgasmassenstrom (trocken)	$\Phi_{f,g nom} \Phi_{f,g part}$	9,4	---	g/s
Rauchgasaustrittstemperatur	$T_{snom} T_{spart}$	300	---	°C
Förderdruck	$p_{nom} p_{part}$	12	---	Pa
Temperaturklasse		T400		
Mehrfachbelegung		Ja		
Lagerung von Brennstoff im Holzfach		Nein		
Maximale Erwärmung des Holzes im Holzfach		---		°C
Feinstaub O ₂ = 13 %	$PM_{nom} PM_{part}$	33	---	mg/Nm ³
CO ₂		9,37	---	%
Abgasemission (CO in den Abgasen bei O ₂ = 13 %)	$CO_{nom} CO_{part}$	0,0930 1162	---	% mg/Nm ³
OGC O ₂ = 13 %	$OGC_{nom} OGC_{part}$	53	---	mg/Nm ³
NO _x O ₂ = 13 %	$NO_{xnom} NO_{xpart}$	79	---	mg/Nm ³
Automatische Abbrandsteuerung		---	---	
Stromverbrauch im Bereitschaftszustand	e_{lsb}	---		kW
Stromverbrauch	$e_{lmax} e_{lmin}$	---	---	kW
Intervallbetrieb Dauerbetrieb	INT CON	INT		

Technische Grunddaten

Hauptabmessungen (Höhe Breite Tiefe)	H W L	1357 876 626	mm
Abmessungen der Brennkammer (Höhe Breite Tiefe)	H W L	545 546 287	mm
Abmessungen der Feuerraumtür (Höhe Breite Tiefe)	H W L	470 650 400	mm
Achshöhe hinterer (seitlichen) Rauchrohanschluss		---	mm
Volumen Wärmetauscher		---	l
Rauchrohrdurchmesser		200	mm
Abgasstutzen	d_{out}	200	mm
Durchmesser zentrale Luftzufuhr		150	mm
Maximale Länge (Rohrleitung) der zentralen Luftzufuhr		6000	mm
Gewicht	m	247	kg

Heizleistung (Brennwert)

mindestraumgröße für die Installation des Produkts

Wärmedämmung des Hauses – sehr gut (20 W/m ³)	z.B. neues, isoliertes Haus / ständig bewohnt	308	m ³
Wärmedämmung des Hauses – gut (22,5 W/m ³)		274	m ³
Wärmedämmung des Hauses – mittel (32 W/m ³)		193	m ³
Wärmedämmung des Hauses – schlecht (45 W/m ³)		137	m ³
Wärmedämmung des Hauses – sehr schlecht (50 W/m ³)	z.B. altes, ungedämmtes Haus / Hütte / Chalet	123	m ³

Abstand zu brennbaren Materialien
Bemerkung

Rückwand	d_R	0	mm
Strahlungsbereich	d_P d_{P1}	1000	800
Strahlungsbereich zum Boden	d_F d_{F1}	340	300
Seitenwände	d_S d_{S1}	270	270
Seite – Nische	d_{S2}	---	mm
Seite – Ausrichtung 45°	d_{S3}	---	mm
Seitliche Strahlung	d_L d_{L1}	330	280
Von dem Boden	d_B	100	mm
Decke	d_C	500	mm
Von der hinteren- und seitlichen Kante des Kamineinsatzes bis zur Innenseite der Isolierung	d_{S4}	120	mm

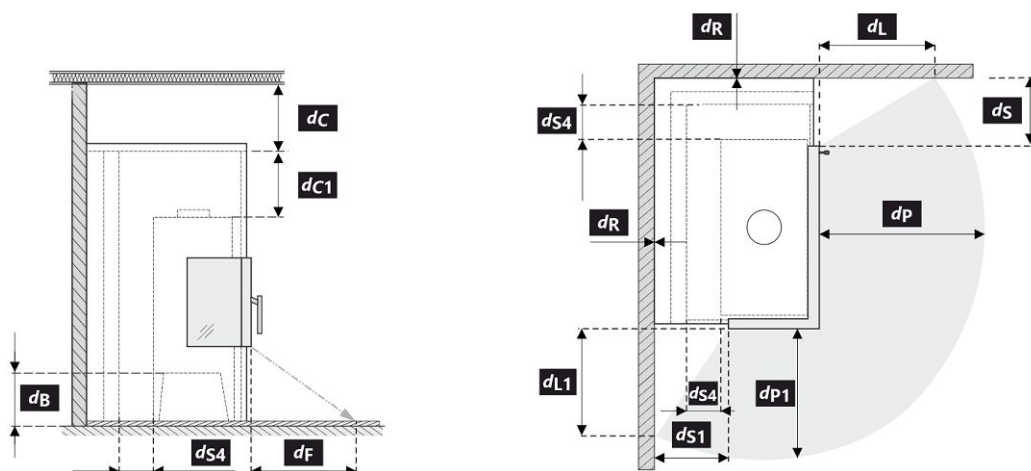

Bei der Installation und dem Betrieb des Ofens sind alle örtlichen Vorschriften sowie nationale und europäische Normen zu beachten.

Legende	Bemerkung	Beschreibung	Material	Maß
1	Gerät		174Q 0000 003	
2	Rauchgasabgang		metall	DN200
3	Isolierung Anschluss Rauchgasabgang			
4	Mineralwolleisolierung			
5	Konvektionsraum um das Gerät			
6	Schutzisolierung der Wände		SILCA 250	2x50 mm
6A	Schutzisolierung der Decke		SILCA 250	80 mm
7	Schutzwand		gebrannter hohlziegel	100 mm
8	Brennbare Wand			

9	Betonplatte		
10	Brennbarer Boden		
11	Dekorativer Träger		
12	Träger mit Belüftungsspalt		
13	Konvektionslufteinlass		700 cm ²
14	Konvektionsluftauslass		900 cm ²
15	Verkleidung	SILCA 250	40 mm
16	Tragrahmen		
17	Brennbare Decke		
18	Schutzisierungsplatte des brennbaren Bodens	SILCA 250	40 mm
19	Verbrennungsluftregulierung		
20	Blechabdeckung bei Verwendung von Mineralwolle		
21	Falls nötig eine Bodenschutzplatte unter dem Gerät		
d_c	Von der Oberkante der Abluftöffnung bis zur brennbaren Decke		500 mm
d_{c1}	- Von der Oberkante des Kamineinsatzes bis zur Unterkante der Deckenisolierung		300 mm
	- Im Falle eines eingebauten Wärmetauschers - von der Oberkante des Wärmetauschers bis zur Unterseite der Deckenisolierung		200 mm
d_{s4}	Von der hinteren- und seitlichen Kante des Kamineinsatzes bis zur Innenseite der Isolierung		120 mm
d_{s5}	Von der Vorder Kante des Kamineinsatzes bis zur Innenseite der Isolierung		10 mm
d_B	Von der Unterseite des Kamineinsatzes bis zum feuerfesten Boden		100 mm

Warnhinweise: Brandschutz- / Dämmplatten SILCA® 250SB kann durch ein geeignetes nicht brennbares Material mit einer Wärmeleitfähigkeit (λ) $\leq 1,1 \text{ W}\cdot\text{m}^{-1}\cdot\text{K}^{-1}$ ersetzt werden.

Schutzwand – gebrannter Hohlziegel (Dicke 100 mm) kann durch ein geeignetes nicht brennbares Material mit einer Wärmeleitfähigkeit (λ) $\leq 0,36 \text{ W}\cdot\text{m}^{-1}\cdot\text{K}^{-1}$ ersetzt werden.

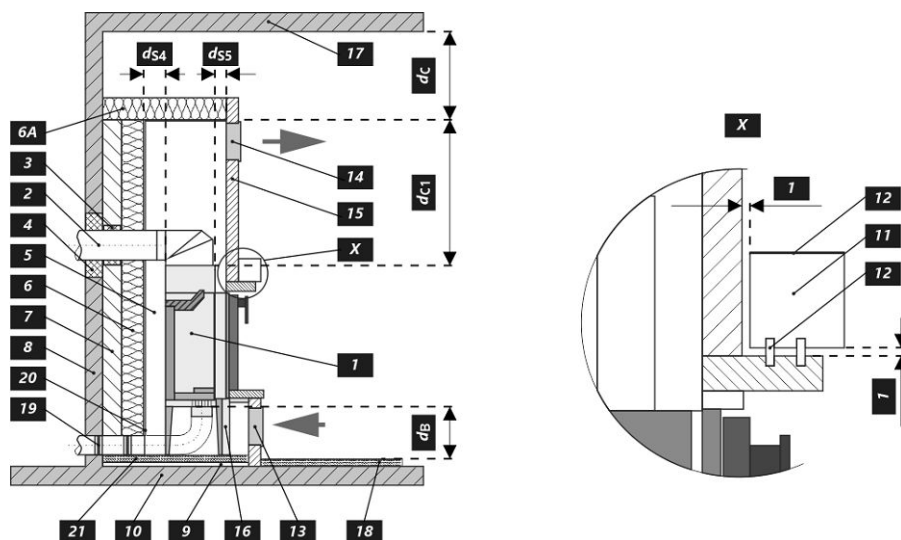

Caractéristiques déclarées du produit

 Norme(s) Européennes EN 16510-1 ed.2:2023 | EN 16510-2-2:2022 Ecodesign DIN+ BImSchV2 15a B-VG 2015

Classification de l'appareil	Type BE			
		Puissance thermique nominale (nom)	Puissance thermique partielle (part)	
Efficacité énergétique	$\eta_{nom} \eta_{part}$	81	---	%
Efficacité énergétique saisonnier à la puissance thermique nominale de l'appareil	$\eta_{snom} \eta_{spart}$	71	---	%
Indice d'efficacité énergétique EEI	EEI	107		
Label énergétique		A+		
Combustible		Bûches		
Longueur recommandée de bûches		180-350		mm
Consommation moyenne de combustible		3,12	---	kg/h
Charge en bois autorisé		4,1		kg/h
Intervalle entre les chargements de combustible		1 heure		
Couche de base du combustible		0,31	---	kg
Critère de fin du cycle d'essai		4,0	---	Vol.-%
Débit massique des fumées		39,5		m ³ /h
Puissance thermique nominale	$P_{nom} P_{part}$	10,4	---	kW
Puissance thermique nominale de l'échangeur	$P_{Wnom} P_{Wpart}$	---	---	kW
Pression d'eau maximale	P_W	---		bar
Débit massique des gaz de combustion secs	$\Phi_{f,g nom} \Phi_{f,g part}$	9,4	---	g/s
Température de sortie des gaz de combustion	$T_{snom} T_{spart}$	300	---	°C
Tirage de conduit de fumée	$P_{nom} P_{part}$	12	---	Pa
Classe de température		T400		
Raccordement à une cheminée collective		Oui		
Stockage du combustible dans range bûches		Non		
Réchauffement maximal du bois dans range bûches		---		°C
Poussière O ₂ = 13 %	$PM_{nom} PM_{part}$	33	---	mg/Nm ³
CO ₂		9,37	---	%
Résidus de combustion émis (CO dans les résidus de combustion pour O ₂ = 13 %)	$CO_{nom} CO_{part}$	0,0930 1162	---	% mg/Nm ³
OGC O ₂ = 13 %	$OGC_{nom} OGC_{part}$	53	---	mg/Nm ³
NOx O ₂ = 13 %	$NO_{xnom} NO_{xpart}$	79	---	mg/Nm ³
Régulation automatique de la combustion		---	---	
Consommation d'énergie en mode veille	e_{lSB}	---		kW
Consommation d'électricité	$e_{lmax} e_{lmin}$	---	---	kW
Fonctionnement par intermittence Service ininterrompu	INT CON	INT		

Données techniques de base

Dimensions principales (Hauteur Largeur Profondeur)	H W L	1357 876 626	mm
Dimensions de la chambre de combustion (Hauteur Largeur Profondeur)	H W L	545 546 287	mm
Dimensions de la porte (Hauteur Largeur Profondeur)	H W L	470 650 400	mm
Hauteur de l'axe de la sortie arrière (latérale)		---	mm
Volume de l'échangeur de chaleur		---	l
Diamètre du conduit de fumée		200	mm
Diamètre de buse d'air de combustion	d_{out}	200	mm
Diamètre de l'arrivée d'air centrale		150	mm
Longueur maximale (tuyau) d'arrivée d'air centrale		6000	mm
Poids	m	247	kg

Capacité thermique (Pouvoir calorifique)

taille minimale de la pièce où est installé l'appareil

Isolation de la maison – très bon (20 W/m ³)	par exemple, maison neuve et isolée / habitée en permanence	308	m ³
Isolation de la maison – bon (22,5 W/m ³)		274	m ³
Isolation de la maison – moyen (32 W/m ³)		193	m ³
Isolation de la maison – mauvais (45 W/m ³)		137	m ³
Isolation de la maison – très mauvais (50 W/m ³)	par exemple une vieille maison / chalet / chalet non isolé	123	m ³

Distance par rapport aux matériaux combustibles

Note

Arrière	d_R	0	mm
Avant	d_P d_{P1}	1000	800
Avant (par rapport au sol)	d_F d_{F1}	340	300
Latéral	d_S d_{S1}	270	270
Latéral – niche	d_{S2}	---	mm
Latéral – emplacement 45°	d_{S3}	---	mm
Rayonnement latéral	d_L d_{L1}	330	280
Depuis le sol	d_B	100	mm
Plafond	d_C	500	mm
Du bord arrière et latéral de l'insert de cheminée jusqu'à l'intérieur de l'isolation	d_{S4}	120	mm

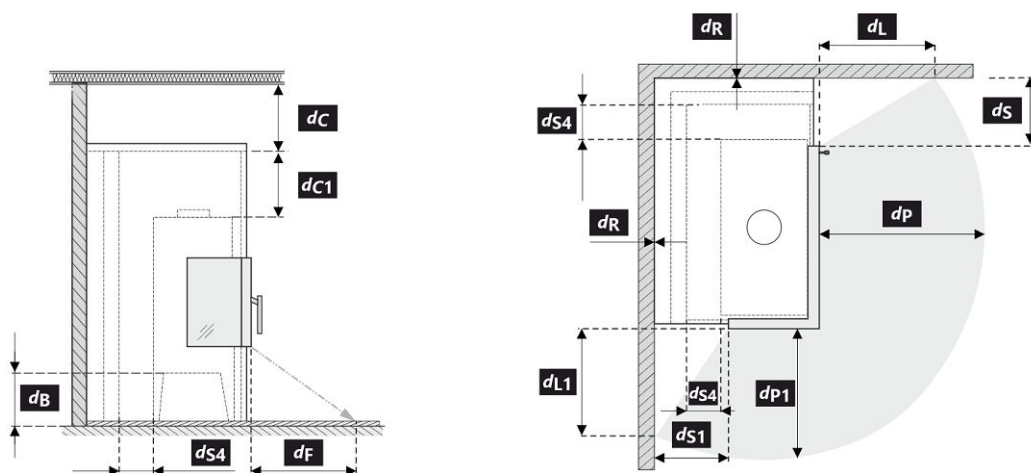

Lors de l'installation et de l'utilisation du produit, toutes les réglementations locales doivent être respectées, y compris celles relatives aux normes nationales et européennes.

Légende	Note	Description	Matériel	Dimension
1		Appareil ménager	174Q 0000 003	
2		Extraction des résidus de combustion	métal	DN200
3		Isolation du raccordement des résidus de combustion		
4		Isolation minérale		
5		Espace de convection autour de l'appareil		
6		Isolation protectrice des murs	SILCA 250	2x50 mm
6A		Isolation protectrice des plafonds	SILCA 250	80 mm
7		Mur de protection	brique creuse cuite	100 mm
8		Mur inflammable		

9	Plaque de béton		
10	Sol inflammable		
11	Support décoratif / ornemental		
12	Support avec espace de ventilation		
13	Entrée d'air de convection		700 cm ²
14	Sortie d'air de convection		900 cm ²
15	Habillage	SILCA 250	40 mm
16	Cadre de support		
17	Plafond inflammable		
18	Panneau isolant de protection pour sols combustibles	SILCA 250	40 mm
19	Régulation de l'air de combustion		
20	Couverture en tôle si de la laine minérale est utilisée		
21	Si nécessaire, une plaque de sol de protection située sous l'appareil		
d_c	Du haut du conduit d'évacuation au plafond combustible		500 mm
d_{c1}	- Du haut de l'insert de cheminée jusqu'au bas de l'isolation du plafond		300 mm
	- Dans le cas d'un échangeur de chaleur installé - du bord supérieur de l'échangeur de chaleur à la partie inférieure de l'isolation du plafond		200 mm
d_{s4}	Du bord arrière et latéral de l'insert de cheminée jusqu'à l'intérieur de l'isolation		120 mm
d_{s5}	Du bord avant de l'insert de cheminée à l'intérieur de l'isolation		10 mm
d_B	Du bas de l'insert de cheminée jusqu'au sol incombustible		100 mm

Avertissement: Panneaux ignifuges / isolants SILCA® 250SB peut être remplacé par un matériau non combustible approprié avec une conductivité thermique (λ) $\leq 1,1 \text{ W}\cdot\text{m}^{-1}\cdot\text{K}^{-1}$.

Mur de protection – brique creuse cuite (épaisseur 100 mm) peut être remplacée par un matériau non combustible adéquat présentant une conductivité thermique (λ) $\leq 0,36 \text{ W}\cdot\text{m}^{-1}\cdot\text{K}^{-1}$.

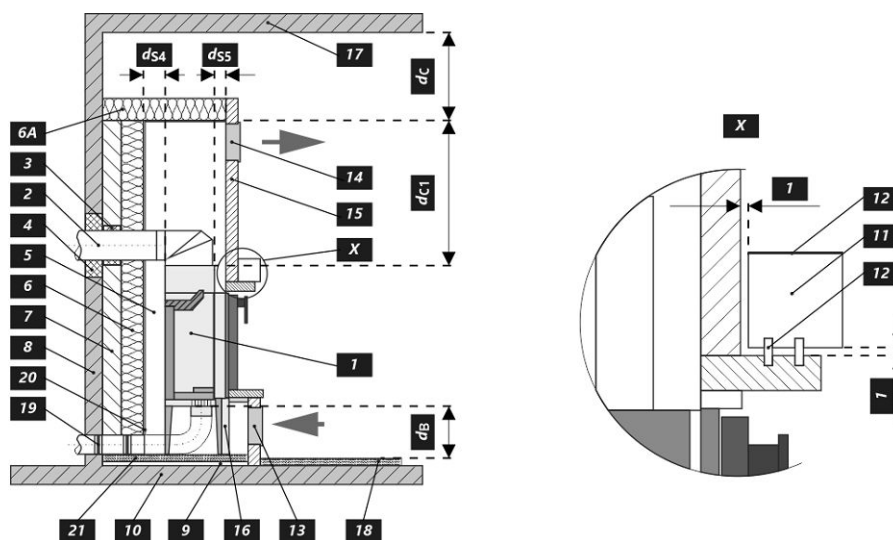

Proprietà dichiarate del prodotto

 Specificazioni tecniche armonizzate EN 16510-1 ed.2:2023 | EN 16510-2-2:2022 Ecodesign DIN+ BImSchV2 15a B-VG 2015

Classificazione del prodotto		Type BE		
		Potenza termica nominale (nom)	Potenza termica parziale (part)	
Efficienza energetica	$\eta_{nom} \eta_{part}$	81	---	%
Efficienza energetica stagionale del riscaldamento d'ambiente	$\eta_{s_{nom}} \eta_{s_{part}}$	71	---	%
Indice di efficienza prodotto	EEI	107		
Etichetta energetica		A+		
Combustibile		Legna		
Combustibile – lunghezza		180-350		mm
Consumo medio di combustibile		3,12	---	kg/h
Dose ammessa di combustibile		4,1		kg/h
Intervallo di aggiunta di combustibile		1 ora		
Strato di base del combustibile		0,31	---	kg
Criterio per la fine del ciclo di test		4,0	---	Vol.-%
Quantità di aria di combustione		39,5		m ³ /h
Potenza termica nominale	$P_{nom} P_{part}$	10,4	---	kW
Potenza ter. nom. dello scambiatore di acqua calda	$P_{Wnom} P_{Wpart}$	---	---	kW
Ppressione massima di funzionamento dell'acqua	P_W	---		bar
Portata dei fumi di scarico secchi	$\Phi_{f,g\ nom} \Phi_{f,g\ part}$	9,4	---	g/s
Temperatura d'uscita dei gas di scarico	$T_{s_{nom}} T_{s_{part}}$	300	---	°C
Tiro di esercizio	$P_{nom} P_{part}$	12	---	Pa
Classe di temperatura del camino		T400		
Collegamento al camino collettivo		Sì		
Stoccaggio del combustibile nell'area della stufa a legna		No		
Riscaldamento massimo della legna nella stufa a legna		---		°C
Polvere O ₂ = 13 %	$PM_{nom} PM_{part}$	33	---	mg/Nm ³
CO ₂		9,37	---	%
Emissioni (CO nei gas comburenti all' O ₂ = 13 %)	$CO_{nom} CO_{part}$	0,0930 1162	---	% mg/Nm ³
OGC O ₂ = 13 %	$OGC_{nom} OGC_{part}$	53	---	mg/Nm ³
NOx O ₂ = 13 %	$NO_{xnom} NO_{xpart}$	79	---	mg/Nm ³
Controllo automatico della combustione		---	---	
Consumo di energia elettrica in modo stand-by	$e_{l_{SB}}$	---		kW
Consumo di energia elettrica	$e_{l_{max}} e_{l_{min}}$	---	---	kW
Funzionamento intermittente Funzionamento continuo	INT CON	INT		

Dati tecnici di base

Dimensioni principali (Altezza Larghezza Profondità)	H W L	1357 876 626	mm
Dimensioni della camera di combustione (Altezza Larghezza Profondità)	H W L	545 546 287	mm
Dimensioni dello sportello del focolare (Alt. Larg. Prof.)	H W L	470 650 400	mm
Altezza dell'asse dell'uscita posteriore (laterale)		---	mm
Volume dello scambiatore di acqua calda		---	l
Diametro del condotto fumario		200	mm
Diametro del gola della canna fumaria	d_{out}	200	mm
Diametro dell'afflusso centralizzato di aria		150	mm
Lunghezza mass. (tubo) di alimentazione centrale dell'aria		6000	mm
Peso	m	247	kg

Capacità termica (Potere calorifico)

dimensione minima del locale in cui è installato l'apparecchio

Isolamento della casa – molto buono (20 W/m ³)	ad esempio, casa nuova e isolata / abitata in modo permanente	308	m ³
Isolamento della casa – buono (22,5 W/m ³)		274	m ³
Isolamento della casa – medio (32 W/m ³)		193	m ³
Isolamento della casa – cattivo (45 W/m ³)		137	m ³
Isolamento della casa – molto male (50 W/m ³)	ad esempio, una vecchia casa / un cottage / uno chalet non isolato	123	m ³

Distanza di materiali infiammabili

		Nota		
Posteriore	d _R	0		mm
Anteriore	d _P d _{P1}	1000	800	mm
Anteriore (rispetto al pavimento)	d _F d _{F1}	340	300	mm
Laterali	d _S d _{S1}	270	270	mm
Laterali – nicchia	d _{S2}	---		mm
Laterali – posizione 45°	d _{S3}	---		mm
Radiazione laterale	d _L d _{L1}	330	280	mm
Dal pavimento	d _B	100		mm
Dal soffitto	d _C	500		mm
Dal bordo posteriore e laterale dell'insero del caminetto fino all'interno dell'isolazione	d _{S4}	120		mm

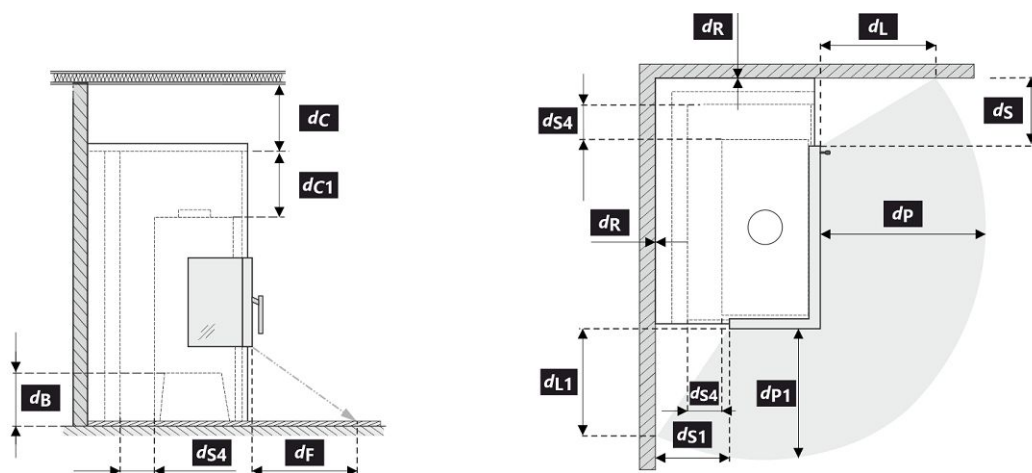

Durante il montaggio e l'uso del prodotto, devono essere rispettate tutte le normative locali, incluse le norme nazionali ed europee.

Legenda	Nota	Descrizione	Materiale	Dimensione
1		Apparecchio	174Q 0000 003	
2		Scarico fumi	metallo	DN200
3		Isolamento del raccordo scarico fumi		
4		Isolamento minerale		
5		Spazio d'aria di convezione intorno all'insero		
6		Isolazione della parete	SILCA 250	2x50 mm
6A		Isolazione del soffitto	SILCA 250	80 mm
7		Parete di protezione	refrattario trafialto	100 mm
8		Parete incombustibile		

9	Lastra di calcestruzzo		
10	Pavimento in infiammabile		
11	Trave decorativa		
12	Trave con intercapedine di ventilazione		
13	Ingresso aria di convezione		700 cm ²
14	Uscita aria di convezione		900 cm ²
15	Rivestimento	SILCA 250	40 mm
16	Telaio di supporto		
17	Soffitto infiammabile		
18	Pannello isolante protettivo per pavimenti infiammabili	SILCA 250	40 mm
19	Gestione dell'aria comburente		
20	Copertura in lamiera con utilizzo di lana di roccia		
21	Se necessario, piastra di protezione sotto l'apparecchio		
d_c	Dall'alto della bocchetta aria superiore al soffitto combustibile		500 mm
d_{c1}	- Dalla parte superiore dell'inserito caminetto alla parte inferiore dell'isolazione del soffitto		300 mm
	- In caso di utilizzo scambiatore di calore, dal bordo superiore dello scambiatore alla parte inferiore dell'isolamento del soffitto		200 mm
d_{s4}	Dal bordo posteriore e laterale dell'inserito del caminetto fino all'interno dell'isolazione		120 mm
d_{s5}	Dal bordo anteriore dell'inserito caminetto fino all'interno dell'isolazione		10 mm
d_B	Dal fondo dell'inserito caminetto al pavimento ignifugo		100 mm

Avviso: I pannelli di protezione antincendio / isolamento SILCA® 250SB possono essere sostituiti da un materiale non infiammabile adatto con una conduttività termica $(\lambda) \leq 1,1 \text{ W}\cdot\text{m}^{-1}\cdot\text{K}^{-1}$.

Parete di protezione – refrattario trafialto (spessore 100 mm) possono essere sostituiti da un materiale non infiammabile adatto con una conduttività termica $(\lambda) \leq 0,36 \text{ W}\cdot\text{m}^{-1}\cdot\text{K}^{-1}$.

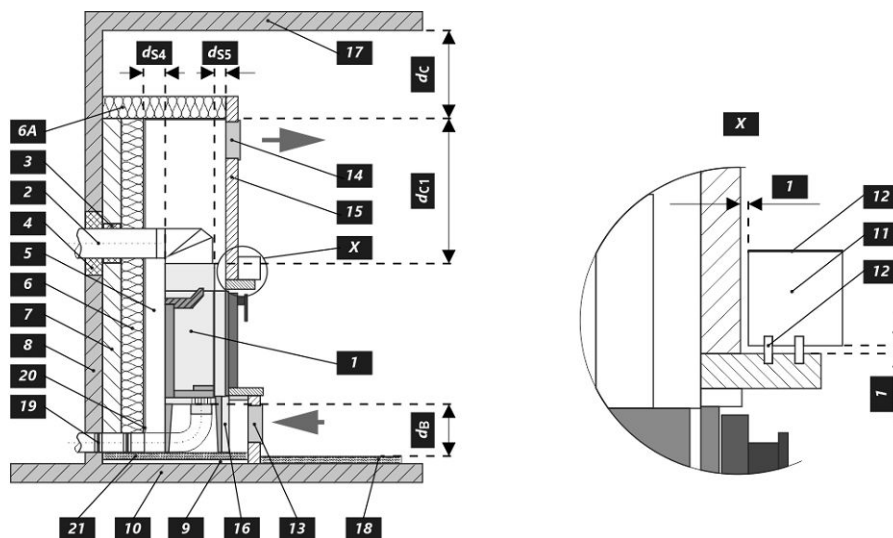

Deklaracija lastnosti

Harmonizirana tehnična specifikacija ✓ EN 16510-1 ed.2:2023 | EN 16510-2-2:2022 ✓ Ecodesign ✓ DIN+ ✓ BImSchV2 ✓ 15a B-VG 2015

Klasifikacija izdelka	Type BE		
		Nazivna toplotna moč (nom)	Toplotna moč pri delni obremenitvi (part)
Energetska učinkovitost	η_{nom} η_{part}	81	---
Sezonska energetska učinkovitost pri ogrevanju prostorov	$\eta_{s,nom}$ $\eta_{s,part}$	71	---
Indeks energetske učinkovitosti	EEI	107	
Energijska nalepka		A+	
Gorivo		Drva	
Priporočljiva dolžina goriva		180-350	
Povprečna poraba lesa		3,12	---
Dovoljena količina lesa		4,1	
Interval dobave goriva za nazivno moč		1 ura	
Osnovni sloj goriva		0,31	---
Merilo za zaključek preskusnega cikla		4,0	---
Zahtevan zrak za izgorevanje		39,5	
Nazivna toplotna moč	P_{nom} P_{part}	10,4	---
Izhod toplovodnega izmenjevalnika	$P_{W,nom}$ $P_{W,part}$	---	---
Maks. delovni tlak	P_W	---	
Masni pretok suhih dimnih plinov	$\Phi_{f,g,nom}$ $\Phi_{f,g,part}$	9,4	---
Temperatura izhodnih dimnih plinov	$T_{s,nom}$ $T_{s,part}$	300	---
Vlek dimnika	P_{nom} P_{part}	12	---
Temperaturni razred kamina		T400	
Priključek na skupni dimnik		Da	
Skladiščenje goriva v območju peči		Ne	
Maksimalno segrevanje lesa v območju peči na drva		---	
Prah O ₂ = 13 %	PM_{nom} PM_{part}	33	---
CO ₂		9,37	---
Emisije izgorovalnih plinov (CO v dimne pline pri O ₂ = 13 %)	CO_{nom} CO_{part}	0,0930 1162	---
OGC O ₂ = 13 %	OGC_{nom} OGC_{part}	53	---
NOx O ₂ = 13 %	$NO_{x,nom}$ $NO_{x,part}$	79	---
Avtomatska regulacija gorenja		---	---
Poraba električne energije v stanju pripravljenosti	$e_{l,SB}$	---	
Poraba električne energije	$e_{l,max}$ $e_{l,min}$	---	---
Prekinjeno delovanje Neprekinjeno delovanje	INT CON	INT	

Osnovni tehnični podatki

Dimenzije (Višina Širina Globina)	H W L	1357 876 626	mm
Dimenzije zgorevalne komore (Višina Širina Globina)	H W L	545 546 287	mm
Dimenzije vrat peči (Višina Širina Globina)	H W L	470 650 400	mm
Višina osi zadnjega (stranskega) izpusta		---	mm
Prostornina toplotnega izmenjevalnika		---	l
Premer priključka dimne cevi		200	mm
Premer dimne cevi	d_{out}	200	mm
Zunanji dovod zraka (ZDZ)		150	mm
Največja dolžina (cevi) zunanje dovod zraka		6000	mm
Teža	m	247	kg

Moč ogrevanja (Kurilna vrednost)

najmanjša velikost prostora primerne za vgradnjo naprave

Izolacija hiše – zelo dobro (20 W/m ³)	npr. nova, izolirana hiša / stalno naseljena	308	m ³
Izolacija hiše – dobro (22,5 W/m ³)		274	m ³
Izolacija hiše – srednja (32 W/m ³)		193	m ³
Izolacija hiše – slabo (45 W/m ³)		137	m ³
Izolacija hiše – zelo slabo (50 W/m ³)	npr. stara, neizolirana hiša / koča / brunarica	123	m ³

Varna razdalja od vnetljivih materialov
Opomba

Zadaj	d_R	0	mm
Spredaj	d_P d_{P1}	1000	800
Stran od tal	d_F d_{F1}	340	300
Stran	d_S d_{S1}	270	270
Stran – niša	d_{S2}	---	mm
Stran – postavitvev pod kotom 45°	d_{S3}	---	mm
Stransko sevanje	d_L d_{L1}	330	280
Od tal	d_B	100	mm
Od stropa	d_C	500	mm
Od zadnjega in stranskega roba kaminskega vložka do notranje strani izolacije	d_{S4}	120	mm

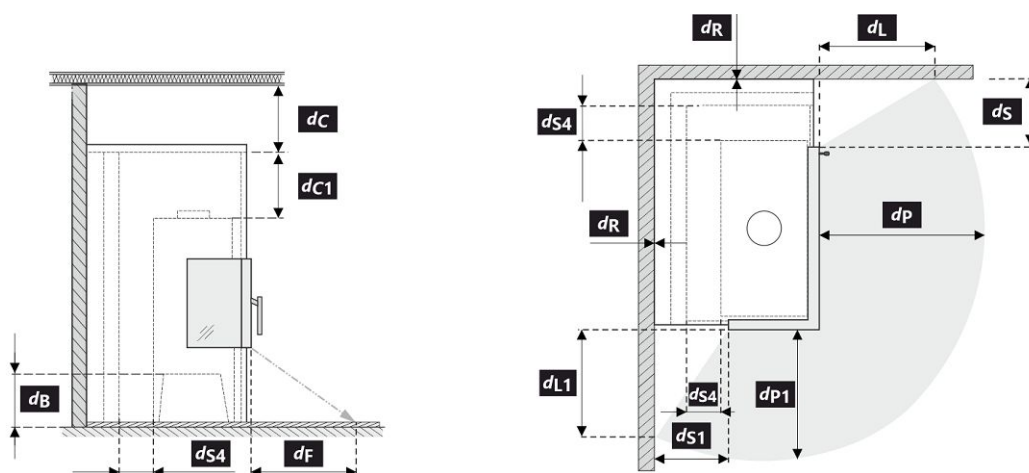

Pri montaži in delovanju izdelka morajo biti upoštevani vsi lokalni predpisi, vključno predpisi, ki se nanašajo na lokalne in Evropske standarde.

Legenda	Opomba	Opis	Material	Dimenzija
1		Naprava	174Q 0000 003	
2		Odvod dimnih plinov	kov	DN200
3		Izolacija priključka za odvod dimnih plinov		
4		Mineralna izolacija		
5		Konvekcijski zračni prostor okoli naprave		
6		Zaščitna izolacija sten	SILCA 250	2x50 mm
6A		Zaščitna izolacija stropa	SILCA 250	80 mm
7		Zaščitna stena	volta žgana opeka	100 mm
8		Groljiva stena		
9		Betonska plošča		

10	Gorljiva podlaga		
11	Dekorativni / okrasni nosilec		
12	Nosilec s prezračevalno zračno režo		
13	Vhod konvekcijskega zraka		700 cm ²
14	Izhod konvekcijskega zraka		900 cm ²
15	Obloga	SILCA 250	40 mm
16	Nosilni okvir		
17	Gorljiv strop		
18	Zaščitna izolacijska deska	SILCA 250	40 mm
19	Regulacija zraka za izgorevanje		
20	Pločevinasti pokrov v primeru uporabe mineralne volne		
21	Po potrebi zaščitna talna plošča pod napravo		
d_c	Od vrha odvoda zraka do gorljivega stropa		500 mm
d_{c1}	– Od vrha kaminskega vložka do spodnje strani stropne izolacije		300 mm
	– Pri vgrajenem toplotnem izmenjevalniku – od zgornjega roba toplotnega izmenjevalnika do spodnje strani stropne izolacije		200 mm
d_{s4}	Od zadnjega in stranskega roba kaminskega vložka do notranje strani izolacije		120 mm
d_{ss}	Od sprednjega roba kaminskega vložka do notranje strani izolacije		10 mm
d_B	Od dna kaminskega vložka do ognjevarne podlage		100 mm

Opomba: Protipožarne / izolacijske plošče SILCA® 250SB se lahko nadomestijo z ustreznim negorljivim materialom s toplotno prevodnostjo (λ) $\leq 1,1 \text{ W}\cdot\text{m}^{-1}\cdot\text{K}^{-1}$.

Zaščitna stena – votla žgana opeka (debeline 100 mm) se lahko nadomestijo z ustreznim negorljivim materialom s toplotno prevodnostjo (λ) $\leq 0,36 \text{ W}\cdot\text{m}^{-1}\cdot\text{K}^{-1}$.

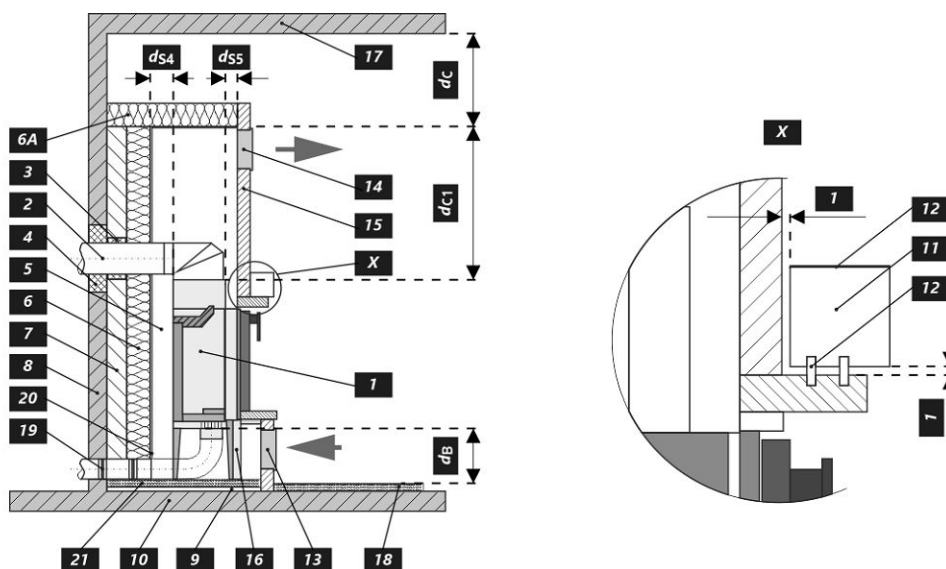

Ilmoitetut ominaisuudet

Yhdenmukaistetut tekniset tiedot ✓ EN 16510-1 ed.2:2023 | EN 16510-2-2:2022 ✓ Ecodesign ✓ DIN+ ✓ BlmSchV2 ✓ 15a B-VG 2015

Laitteen luokittelu	Type BE			
		Nimellinen lämmöntuotto (nom)	Lämmöntuotto osakuormalla (part)	
Energiatehokkuus	$\eta_{nom} \eta_{part}$	81	---	%
Tilojen kausilämmityksen energiatehokkuus at nominal heat output	$\eta_{s,nom} \eta_{s,part}$	71	---	%
Energiatehokkuusindeksi	EEI	107		
Energiamerkintä		A+		
Polttoaine		Puuhalot		
Polttopuun pituus		180-350		mm
Keskimääräinen polttoaineenkulutus		3,12	---	kg/h
Sallittu puumäärä		4,1		kg/h
Puun lisäysväli		1 tunti		
Polttoaineen pohjakerros		0,31	---	kg
Kokeilujakson päättymisen kriteeri		4,0	---	Vol.-%
Palamisilman määrä		39,5		m ³ /h
Nimellinen lämmöntuotto	$P_{nom} P_{part}$	10,4	---	kW
Vesilämmönsiirtimen teho	$P_{W,nom} P_{W,part}$	---	---	kW
Veden maksimi käyttöpain	p_W	---		bar
Kuivan savukaasun massavirta	$\Phi_{f,g,nom} \Phi_{f,g,part}$	9,4	---	g/s
Savukaasujen ulostulolämpötila	$T_{s,nom} T_{s,part}$	300	---	°C
Savuputken veto	$p_{nom} p_{part}$	12	---	Pa
Hormin lämpötilaluokka		T400		
Liitäntä yhteiseen hormiin		Kyllä		
Polttoaineen varastointialue		Ei		
Puun maksimaalinen lämpeneminen varastointialueella		---		°C
Pöly O ₂ = 13 %	$PM_{nom} PM_{part}$	33	---	mg/Nm ³
CO ₂		9,37	---	%
Pölykaasupäästöt (CO savukaasuissa O ₂ = 13 %)	$CO_{nom} CO_{part}$	0,0930 1162	---	% mg/Nm ³
OGC O ₂ = 13 %	$OGC_{nom} OGC_{part}$	53	---	mg/Nm ³
NOx O ₂ = 13 %	$NO_{x,nom} NO_{x,part}$	79	---	mg/Nm ³
Automaattinen palamisen säätöyksikkö		---	---	
Virrankulutus valmiustilassa	$e_{l,SB}$	---		kW
Virrankulutus	$e_{l,max} e_{l,min}$	---	---	kW
Ajoittainen käyttö Jatkuva käyttö	INT CON	INT		

Tekniset perustiedot

Tärkeimmät mitat (Korkeus Leveys Pituus)	H W L	1357 876 626	mm
Palotilan mitat (Korkeus Leveys Pituus)	H W L	545 546 287	mm
Takan luukun mitat (Korkeus Leveys Pituus)	H W L	470 650 400	mm
Takimmaisen (sivu-)ulostuloaukon korkeus		---	mm
Vesilämmönsiirtimen tilavuus		---	l
Hormin halkaisija		200	mm
Savukanavan liitännän halkaisija	d_{out}	200	mm
Ulkoilmaliitännän halkaisija		150	mm
Ulkoisen ilmanoton enimmäispituus (putki)		6000	mm
Paino	m	247	kg

Lämpökapasiteetti

huoneen vähimmäiskoko, johon laite asennetaan

Talon lämmöneristys – erinomainen (20 W/m ³)	esim. uusi lämmöneristetty talo / pysyvästi asuttu	308		m ³
Talon lämmöneristys – hyvä (22,5 W/m ³)		274		m ³
Talon lämmöneristys – tyydyttävä (32 W/m ³)		193		m ³
Talon lämmöneristys – vähäinen (45 W/m ³)		137		m ³
Talon lämmöneristys – erittäin huono (50 W/m ³)	esim. vanha, lämmöneristämätön talo / mökki / alppimaja	123		m ³

Kaugus süttivatest materjalidest

Märkus

Tagaosa	d_R	0		mm
Esiosa	d_P d_{P1}	1000	800	mm
Esiosast põrandani	d_F d_{F1}	340	300	mm
Külg	d_S d_{S1}	270	270	mm
Külg – nišš	d_{S2}	---		mm
Külg – asend 45°	d_{S3}	---		mm
Kiirgus külje suunas	d_L d_{L1}	330	280	mm
Põrandast	d_B	100		mm
Laest	d_C	500		mm
Kaminasüdamiku tagumisest ja külgmisest nurgast isolatsioonini sisemiseni	d_{S4}	120		mm

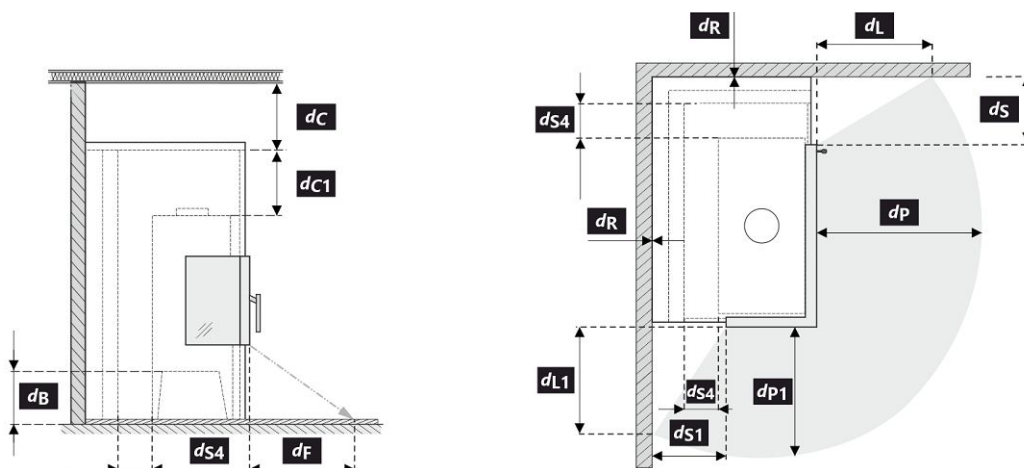

Toote paigaldamise ja kasutamise ajal tuleb järgida kõiki kohalikke määrusi, kaasa arvatud siseriiklikest ja Euroopa standarditest tulenevad määrused.

Nr	Märkus	Kirjeldus	Materjal	Mõõdud
1		Seade	174Q 0000 003	
2		Suitsugaasi väljalasketoru	metall	DN200
3		Suitsugaasi ühenduse soojustus		
4		Mineraalvill		
5		Konvektsiooni õhuruum seadme ümber		
6		Seinte kaitsekiht	SILCA 250	2x50 mm
6A		Seinte kaitsekiht	SILCA 250	80 mm
7		Kaitsesein	põletatud õõnestellis	100 mm
8		Põlev seinamaterjal		

9	Betoonplaat		
10	Põlev pörandamaterjal		
11	Dekoratiivne / mustriiline tala		
12	Ventilatsiooni õhupiluga tala		
13	Konvektsiooni sissepuhkevõre		700 cm ²
14	Konvektsiooni väljapuhkevõre		900 cm ²
15	Vooder	SILCA 250	40 mm
16	Tugiraam		
17	Põlev laematerjal		
18	Põlevast materjalist pörandat kaitsev soojustusplaat	SILCA 250	40 mm
19	Põlemisõhu reguleerimine		
20	Metallkate, kui kasutatakse mineraalvilla		
21	Vajdusel seadmealuse pöranda kaitseplaat		
d_c	Väljatõmbeventilatsiooni otsast põleva laematerjalini		500 mm
d_{c1}	– Kaminasüdamiku tipust lae soojustuse alumise pooleni		300 mm
	– Kui on paigaldatud soojusvaheti, siis soojusvaheti ülemisest nurgast lae soojustuse alumise pooleni		200 mm
d_{s4}	Kaminasüdamiku tagumisest ja külgmisest nurgast soojustuse sisepinnani		120 mm
d_{s5}	Kaminasüdamiku eesmisest nurgast soojustuse sisepinnani		10 mm
d_B	Kaminsaüdamiku põhjast tulekindla pörandani		100 mm

Hoiatus: Tuletõkke- / isolatsiooniplaadid SILCA® 250SB võib asendada sobiva mittesüttiva materjaliga, mille soojusjuhtivus on $(\lambda) \leq 1,1 \text{ W}\cdot\text{m}^{-1}\cdot\text{K}^{-1}$.

Kaitsesein – põletatud õonestellis (paksus 100 mm) võib asendada sobiva mittesüttiva materjaliga, mille soojusjuhtivus on $(\lambda) \leq 0,36 \text{ W}\cdot\text{m}^{-1}\cdot\text{K}^{-1}$.

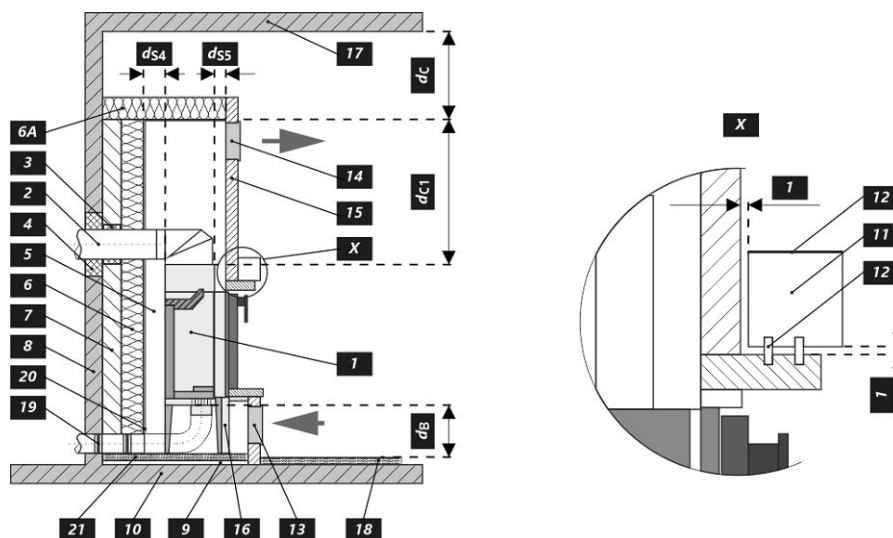

Deklareeritud omadused

Harmoneeritud tehniline spetsifikatsioon ✓ EN 16510-1 ed.2:2023 | EN 16510-2-2:2022 ✓ Ecodesign ✓ DIN+ ✓ BImSchV2 ✓ 15a B-VG 2015

Seadme klassifikatsioon	Type BE		
	Nimivõimsuse juures (nom)	Osalise võimsuse juures (part)	
Energiaühik	$\eta_{nom} \eta_{part}$	81	---
Kütmise sesoonne energiaühik	$\eta_{s,nom} \eta_{s,part}$	71	---
Energiaühikude indeks	EEI	107	
Energiamärgis		A+	
Küttematerjal		Puuhalud	
Küttematerjali pikkus		180-350	
Keskmine küttematerjali tarve		3,12	---
Lubatud küttematerjali hulk		4,1	
Küttematerjali lisamise intervall		1 tund	
Kütuse aluskiht		0,31	---
Katse tsükli lõpetamise kriteerium		4,0	---
Põlemisõhu hulk		39,5	
Nimivõimsus	$P_{nom} P_{part}$	10,4	---
Soojusvaheti võimsus	$P_{W,nom} P_{W,part}$	---	---
Maksimaalne veesurve	P_W	---	
Suitsugaaside kuivmass määr	$\Phi_{f,g,nom} \Phi_{f,g,part}$	9,4	---
Suitsugaaside temperatuur lõõrist väljumisel	$T_{s,nom} T_{s,part}$	300	---
Suitsutoru tõmme	$P_{nom} P_{part}$	12	---
Korstna temperatuuriklass		T400	
Ühendus üldkorstnaga		Jah	
Küttematerjali ladustamine puude säilitusalal		Ei	
Puidu maksimaalne soojenemine säilitusalal		---	
Tolm O ₂ = 13 %	$PM_{nom} PM_{part}$	33	---
CO ₂		9,37	---
Põlemisgaaside emissioon suitsugaaside CO kui O ₂ = 13 %)	$CO_{nom} CO_{part}$	0,0930 1162	---
OGC O ₂ = 13 %	$OGC_{nom} OGC_{part}$	53	---
NOx O ₂ = 13 %	$NO_{x,nom} NO_{x,part}$	79	---
Automaatne põlemise reguleerimisseade		---	---
Elektritarbimine ooterežiimis	$e_{l,SB}$	---	
Energiaarve	$e_{l,max} e_{l,min}$	---	---
Vahelduv töö Pidev töö	INT CON	INT	

Tehnilised põhiaandmed

Põhimõõtmed (Kõrgus Laius Pikkus)	H W L	1357 876 626	mm
Põlemiskambri mõõdud (Kõrgus Laius Pikkus)	H W L	545 546 287	mm
Kolde ukse mõõdud (Kõrgus Laius Pikkus)	H W L	470 650 400	mm
Tagumise (külgmise) väljalaskeava telje kõrgus		---	mm
Sooja vee soojusvaheti maht		---	l
Suitsutoru diameeter		200	mm
Suitsutoru ava diameeter	d_{out}	200	mm
Välisõhu ühenduse diameeter		150	mm
Õhu sissevõtutoru maksimaalne pikkus		6000	mm
Kaal	m	247	kg

Soojusmahutavus

seadme paigaldamiseks sobiva ruumi vähim suurus

Hoone soojustus – väga hea (20 W/m ³)	nt uus soojustatud hoone / hoone, milles elatakse aasta ringi	308	m ³
Hoone soojustus – hea (22,5 W/m ³)		274	m ³
Hoone soojustus – keskmine (32 W/m ³)		193	m ³
Hoone soojustus – halb (45 W/m ³)		137	m ³
Hoone soojustus – väga halb (50 W/m ³)	nt vana soojustamata hoone / suvila	123	m ³

Kaugus süttivatest materjalidest
Märkus

Tagaosa	d_R	0	mm
Esiosa	d_P d_{P1}	1000	800
Esiosast pörandani	d_F d_{F1}	340	300
Külg	d_S d_{S1}	270	270
Külg – nišš	d_{S2}	---	mm
Külg – asend 45°	d_{S3}	---	mm
Kiirgus külje suunas	d_L d_{L1}	330	280
Pörandast	d_B	100	mm
Laest	d_C	500	mm
Kaminasüdamiku tagumisest ja külgmisest nurgast isolatsiooni sisemuseni	d_{S4}	120	mm

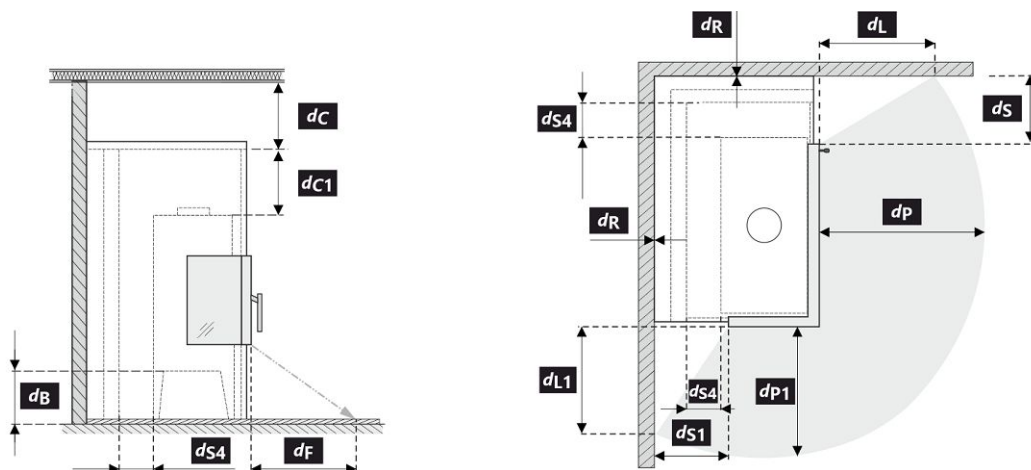

Toote paigaldamise ja kasutamise ajal tuleb järgida kõiki kohalikke määrusi, kaasa arvatud siseriiklikest ja Euroopa standarditest tulenevad määrused.

Nr	Märkus	Kirjeldus	Materjal	Mõõdud
1		Seade	174Q 0000 003	
2		Suitsugaasi väljalasketoru	metall	DN200
3		Suitsugaasi ühenduse soojustus		
4		Mineraalvill		
5		Konvektsiooni õhuruum seadme ümber		
6		Seinte kaitsekiht	SILCA 250	2x50 mm
6A		Lae kaitsekiht	SILCA 250	80 mm
7		Kaitsesein	põletatud õõnestellis	100 mm
8		Põlev seinamaterjal		
9		Betoonplaat		

10	Põlev põrandamaterjal		
11	Dekoratiivne / mustriiline tala		
12	Ventilatsiooni õhupiluga tala		
13	Konvektsiooni sissepuhkevõre		700 cm ²
14	Konvektsiooni väljapuhkevõre		900 cm ²
15	Vooder	SILCA 250	40 mm
16	Tugiraam		
17	Põlev laematerjal		
18	Põlevast materjalist põrandat kaitsev soojustusplaat	SILCA 250	40 mm
19	Põlemisõhu reguleerimine		
20	Metallkate, kui kasutatakse mineraalvilla		
21	Vajdusel seadmealuse põrandat kaitseplaat		
d_c	Väljatõmbeventilatsiooni otsast põleva laematerjalini		500 mm
d_{c1}	– Kaminasüdamiku tipust lae soojustuse alumise pooleni		300 mm
	– Kui on paigaldatud soojusvaheti, siis soojusvaheti ülemisest nurgast lae soojustuse alumise pooleni		200 mm
d_{s4}	Kaminasüdamiku tagumisest ja külgmisest nurgast soojustuse sisepinnani		120 mm
d_{ss}	Kaminasüdamiku eesmisest nurgast soojustuse sisepinnani		10 mm
d_B	Kaminsüdamiku põhjast tulekindla põrandani		100 mm

Hoiatus: Tuletõkke- / isolatsiooniplaadid SILCA® 250SB võib asendada sobiva mittesüttiva materjaliga, mille soojusjuhtivus on $(\lambda) \leq 1,1 \text{ W}\cdot\text{m}^{-1}\cdot\text{K}^{-1}$.

Kaitsesein – põletatud õonestellis (paksus 100 mm) võib asendada sobiva mittesüttiva materjaliga, mille soojusjuhtivus on $(\lambda) \leq 0,36 \text{ W}\cdot\text{m}^{-1}\cdot\text{K}^{-1}$.

